



# ISOMETER® IRDH275BM-7 Coupling device AGH675S-7 and AGH675S-7MV15



**Insulation monitoring device for medium voltage  
IT systems with galvanically connected rectifiers  
and converters up to AC/DC 15.5 kV in combination with  
the coupling devices AGH675S-7 and AGH675S-7MV15**

**optec**  
energie ist messbar

Optec AG | Suyen-Zeller-Strasse 14 | CH-8620 Wetzikon ZH

Telefon: +41 88 933 07 70 / Telefax: +41 88 933 07 77

E-Mail: [info@optec.ch](mailto:info@optec.ch) / Internet: [www.optec.ch](http://www.optec.ch)



## **Bender GmbH & Co. KG**

Londorfer Str. 65 • 35305 Grünberg • Germany

P.O. Box 1161 • 35301 Grünberg • Germany

Tel.: +49 6401 807-0

Fax: +49 6401 807-259

E-mail: [info@bender.de](mailto:info@bender.de)

Web: <http://www.bender.de>

© Bender GmbH & Co. KG

All rights reserved.

Reprinting only with permission  
of the publisher.

Subject to change!

Photos: Bender archives and bendersystembau archives.

## Table of Contents

<b>1. Important information</b>	<b>7</b>
1.1 How to use this manual	7
1.2 Technical support: service and support	8
1.2.1 First level support	8
1.2.2 Repair service	8
1.2.3 Field service	9
1.3 Training courses	9
1.4 Delivery conditions	9
1.5 Inspection, transport and storage	10
1.6 Warranty and liability	10
1.7 Disposal	11
<b>2. Safety instructions</b>	<b>12</b>
2.1 General safety instructions	12
2.2 Work activities on electrical installations	12
2.3 Device-specific safety information	13
2.4 Intended use	15
2.5 Directions for installation	16
<b>3. Function</b>	<b>18</b>
3.1 Characteristics IRDH275BM-7 incl. AGH675S-7...	18
3.2 Product description	19
3.3 Function	19
<b>4. Installation and connection</b>	<b>24</b>
4.1 Installation of the coupling device AGH675S-7...	24
4.2 Wiring diagram	25

<b>5. Operation and setting</b> .....	<b>30</b>
5.1 Operating features and displays IRDH275BM-7 .....	30
5.1.1 Display in the standard mode .....	31
5.1.2 Display in the menu mode .....	31
5.1.3 Function keys .....	32
5.2 Menu structure and menu mode .....	34
5.2.1 Diagram menu structure .....	35
5.3 Menu HISTORY INFO .....	36
5.3.1 Diagram HISTORY INFO .....	37
5.4 Menu ISO SETUP: Setting of the basic ISOMETER® functions .....	38
5.4.1 Response values Alarm 1 and Alarm 2 .....	38
5.4.2 Operating principle of the alarm relays .....	39
5.4.3 Memory setting (on/off) .....	41
5.4.4 Current output for external measuring instruments .....	41
5.5 Menu ISO ADVANCED: Setting of the extended functions .....	42
5.5.1 Coupling devices AGH: 675S-7... .....	42
5.5.2 Adaptation to the system leakage capacitance Cemax .....	42
5.5.3 Measuring principle (Measure: AMP) .....	42
5.5.4 Setting the repetition time for automatic self tests (Autotest: 24h) .....	42
5.5.5 Setting the real-time clock (Clock) .....	42
5.5.6 Setting the date (Date) .....	43
5.5.7 Specifying the starting time of the automatic self test (Test) (IRDH275B) .....	43
5.5.8 Diagram ISO ADVANCED .....	44
5.6 Menu COM SETUP: Setting the BMS interface .....	45
5.6.1 Bus address „Addr:“ .....	45
5.6.2 Diagram COM SETUP .....	46
5.7 Menu PASSWORD .....	47
5.7.1 Activating and setting the password .....	47
5.7.2 Diagram PASSWORD .....	48
5.8 Menu LANGUAGE .....	49

5.8.1	Setting the national language .....	49
5.8.2	Diagram Language .....	49
5.9	Menu SERVICE .....	50
5.10	Parameterization via Internet .....	50
<b>6.</b>	<b>Serial interfaces .....</b>	<b>51</b>
6.1	RS-485 interface with BMS protocol .....	51
6.2	Topology RS-485 network .....	52
6.2.1	Correct arrangement .....	52
6.2.2	Wrong arrangement .....	52
6.2.3	Wiring .....	52
6.3	BMS protocol .....	53
6.3.1	BMS Master .....	53
6.3.2	BMS Slave .....	54
6.3.3	Commissioning of an RS-485 network with BMS protocol .....	55
<b>7.</b>	<b>Technical data IRDH275BM-7 with AGH675S-7... .....</b>	<b>57</b>
7.1	Data in tabular IRDH275BM-7 .....	57
7.2	Standards and approvals .....	60
7.3	Data in tabular AGH675S-7 .....	61
7.4	Data in tabular AGH675S-7MV15 .....	63
7.5	Characteristic curves .....	65
7.6	Ordering details .....	70
7.6.1	ISOMETER® and coupling devices .....	70



# 1. Important information

## 1.1 How to use this manual



*This manual is intended for **qualified personnel** working in electrical engineering and electronics!*

### **Always keep this manual within easy reach for future reference.**

To make it easier for you to understand and revisit certain sections in this manual, we have used symbols to identify important instructions and information. The meaning of these symbols is explained below:



*This signal word indicates that there is a **high risk of danger** that will result in **electrocution** or **serious injury** if not avoided.*



*This signal word indicates a **medium risk of danger** that can lead to **death** or **serious injury** if not avoided.*



*This signal word indicates a **medium risk of danger** that can lead to **death** or **serious injury** if not avoided.*



*This symbol denotes information intended to assist the user in making **optimum use** of the product.*

## 1.2 Technical support: service and support

For commissioning and troubleshooting Bender offers you:

### 1.2.1 First level support

Technical support by phone or e-mail for all Bender products

- Questions concerning specific customer applications
- Commissioning
- Troubleshooting

**Telephone:** +49 6401 807-760\*  
**Fax:** +49 6401 807-259  
In Germany only: 0700BenderHelp (Tel. and Fax)  
**E-mail:** support@bender-service.de

### 1.2.2 Repair service

Repair, calibration, update and replacement service for Bender products

- Repairing, calibrating, testing and analysing Bender products
- Hardware and software update for Bender devices
- Delivery of replacement devices in the event of faulty or incorrectly delivered Bender devices
- Extended guarantee for Bender devices, which includes an in-house repair service or replacement devices at no extra cost

**Telephone:** +49 6401 807-780\*\* (technical issues)  
+49 6401 807-784\*\*, -785\*\* (sales)  
**Fax:** +49 6401 807-789  
**E-mail:** repair@bender-service.de

Please send the devices for **repair** to the following address:

Bender GmbH, Repair-Service,  
Londorfer Str. 65,  
35305 Grünberg



### 1.2.3 Field service

On-site service for all Bender products

- Commissioning, configuring, maintenance, troubleshooting of Bender products
- Analysis of the electrical installation in the building (power quality test, EMC test, thermography)
- Training courses for customers

<b>Telephone:</b>	+49 6401 807-752**, -762 **(technical issues) +49 6401 807-753** (sales)
<b>Fax:</b>	+49 6401 807-759
<b>E-mail:</b>	fieldservice@bender-service.de
<b>Internet:</b>	www.bender-de.com

\*Available from 7.00 a.m. to 8.00 p.m. 365 days a year (CET/UTC+1)

\*\*Mo-Thu 7.00 a.m. - 8.00 p.m., Fr 7.00 a.m. - 13.00 p.m

## 1.3 Training courses

Bender is happy to provide training regarding the use of test equipment. The dates of training courses and workshops can be found on the Internet at [www.bender-de.com](http://www.bender-de.com) -> Know-how -> Seminars.

## 1.4 Delivery conditions

Bender sale and delivery conditions apply.

For software products the "Softwareklausel zur Überlassung von Standard-Software als Teil von Lieferungen, Ergänzung und Änderung der Allgemeinen Lieferbedingungen für Erzeugnisse und Leistungen der Elektroindustrie" (software clause in respect of the licensing of standard software as part of deliveries, modifications and changes to general delivery conditions for products and services in the electrical industry) set out by the ZVEI (Zentralverband Elektrotechnik- und Elektronikindustrie e. V.) (German Electrical and Electronic Manufacturer's Association) also applies.

Sale and delivery conditions can be obtained from Bender in printed or electronic format.

## 1.5 Inspection, transport and storage

Inspect the dispatch and equipment packaging for damage, and compare the contents of the package with the delivery documents. In the event of damage in transit, please contact Bender immediately.

The devices must only be stored in areas where they are protected from dust, damp, and spray and dripping water, and in which the specified storage temperatures can be ensured.

## 1.6 Warranty and liability

Warranty and liability claims in the event of injury to persons or damage to property are excluded if they can be attributed to one or more of the following causes:

- Improper use of the device.
- Incorrect mounting, commissioning, operation and maintenance of the device.
- Failure to observe the instructions in this operating manual regarding transport, commissioning, operation and maintenance of the device.
- Unauthorised changes to the device made by parties other than the manufacturer.
- Non-observance of technical data.
- Repairs carried out incorrectly and the use of replacement parts or accessories not approved by the manufacturer.
- Catastrophes caused by external influences and force majeure.
- Mounting and installation with device combinations not recommended by the manufacturer.

This operating manual, especially the safety instructions, must be observed by all personnel working on the device. Furthermore, the rules and regulations that apply for accident prevention at the place of use must be observed.

## 1.7 Disposal

Abide by the national regulations and laws governing the disposal of this device. Ask your supplier if you are not sure how to dispose of the old equipment.

The directive on waste electrical and electronic equipment (WEEE directive) and the directive on the restriction of certain hazardous substances in electrical and electronic equipment (RoHS directive) apply in the European Community. In Germany, these policies are implemented through the "Electrical and Electronic Equipment Act" (ElektroG). According to this, the following applies:

- Electrical and electronic equipment are not part of household waste.
- Batteries and accumulators are not part of household waste and must be disposed of in accordance with the regulations.
- Old electrical and electronic equipment from users other than private households which was introduced to the market after 13 August 2005 must be taken back by the manufacturer and disposed of properly. For more information on the disposal of Bender devices, refer to our homepage at [www.bender-de.com](http://www.bender-de.com) -> Service & support.

## 2. Safety instructions

### 2.1 General safety instructions

Part of the device documentation in addition to this manual is the enclosed "Safety instructions for Bender products".

### 2.2 Work activities on electrical installations



Only **qualified personnel** are permitted to carry out the work necessary to install, commission and run a device or system.



**DANGER**

---

#### **Risk of electrocution due to electric shock!**

Touching live parts of the system carries the risk of:

- An electric shock
- Damage to the electrical installation
- Destruction of the device

**Before installing and connecting the device, make sure that the installation has been *de-energised*.** Observe the rules for working on electrical installations.

---

If the device is used outside the Federal Republic of Germany, the applicable local standards and regulations must be complied with. The European standard EN 50110 can be used as a guide.

## 2.3 Device-specific safety information



**WARNING**

*Children and unauthorised persons must not have access to or contact with the ISOMETER®.*



**CAUTION**

***Make sure that the operating voltage is correct!***

*Prior to insulation and voltage tests, the ISOMETER® must be disconnected from the IT system for the duration of the test. In order to check the correct connection of the device, a functional test has to be carried out before starting the system.*



**CAUTION**

*Make sure that the basic settings meet the requirements of the IT system.*



*In the event of an alarm message of the ISOMETER®, the insulation fault should be eliminated as quickly as possible.*



*If the ISOMETER® is installed inside a control cabinet, the insulation fault message must be audible and/or visible to attract attention.*



*When using ISOMETER®s in IT systems, make sure that only one active ISOMETER® is connected in each interconnected system. If IT systems are interconnected via coupling switches, make sure that ISOMETER®s not currently used are disconnected from the IT system and deactivated. IT systems coupled via diodes or capacitances may also influence the insulation monitoring process so that a central control of the different ISOMETER®s is required.*



**Prevent measurement errors!**

*When a monitored IT system contains galvanically coupled DC circuits, an insulation fault can only be detected correctly if the rectifier valves (e.g. rectifier diode, thyristors, IGBTs, frequency inverters, ...) carry a minimum current of > 10 mA.*



**Unspecified frequency range**

*When connecting to an IT system with frequency components below the specified frequency range, the response times and response values may differ from the indicated technical data. However, depending on the application and the selected measurement method, continuous insulation monitoring is also possible in this frequency range.*

*There is no influence on the insulation monitoring for IT systems with frequency components above the specified frequency range, e.g. within the range of typical switching frequencies of frequency inverters (2...20 kHz).*

## 2.4 Intended use

The ISOMETER® with additional coupling devices is intended for:

- monitoring the insulation resistance of IT systems.

In order to meet the requirements of the applicable standards, customised parameter settings must be made on the equipment in order to adapt it to local equipment and operating conditions. Please heed the limits of the range of application indicated in the technical data.

Any use other than that described in this manual is regarded as improper.

## 2.5 Directions for installation





### **Risk of property damage due to unprofessional installation!**

*If more than one insulation monitoring device is connected to a conductively connected system, the system can be damaged. If several devices are connected, the device does not function and does not signal insulation faults. Make sure that only one insulation monitoring device is connected in each conductively connected system.*



### **Ensure disconnection from the IT system!**

*When insulation or voltage tests are to be carried out, the device shall be isolated from the system for the test period. Otherwise the device may be damaged.*

The terminals  and KE shall be connected by a separate wire to the protective conductor (PE). If the device is connected by means of terminal AK via the coupling device to a system under operation, the terminals  and KE must not be disconnected from the protective conductor (PE).



### **Check proper connection!**

*Prior to commissioning of the installation, check that the device has been properly connected and check the device functions. Perform a functional test using an earth fault via a resistance that is suitable for the mains voltage.*



The devices, variant -7.. are delivered with the following factory setting:

ISO SETUP	Alarm 1 / Alarm 2 (response values)	= 2 M $\Omega$ / 100 k $\Omega$
ISO SETUP	Operating principle K1/K2	= N/O operation
ISO SETUP	Memory	= off
ISO ADVAN- CED	System leakage capacitance	= 2 $\mu$ F
ISO ADVAN- CED	Coupling device	= AGH: 675S-7
COM SETUP	Bus address	= 3 (slave)

Please check if the basic setting of the ISOMETER® complies with the requirements of the system to be monitored.



*When an AC system includes galvanically connected DC circuits, the following shall be considered:  
Insulation faults in DC circuits can only be monitored correctly when the rectifiers carry a continuous load of 5...10 mA.*

## 3. Function

### 3.1 Characteristics IRDH275BM-7 incl. AGH675S-7...

- Device combination for use in medium voltage systems with converters up to AC/DC 15.5 kV (IT = ungrounded systems))
- Automatic adaptation to the existing system leakage capacitance
- **AMPPlus** measuring principle (European Patent: EP 0 654 673 B1)
- Two separately adjustable ranges of the response value 100 k $\Omega$ ... 10 M $\Omega$  (Alarm 1, Alarm 2)
- Two-line LC display
- Automatic device self test
- Memory with real-time clock to store all alarm messages with date and time stamp.
- BMS interface (BMS protocol) for data exchange with other Bender devices (RS-485 electrically isolated).
- Current output 0 (4)...20mA (galvanically separated) in relation to the measured insulation value.
- Remote setting of certain parameters via the Internet (option; protocol converter FTC470XET additionally required)

## 3.2 Product description

- The ISOMETER® IRDH275BM-7 and coupling device AGH675S-7 monitor the insulation resistance of IT medium voltage systems up to 7.2 kV.
- The ISOMETER® IRDH275BM-7 and two coupling devices AGH675S-7MV15 monitor the insulation resistance of IT medium voltage systems up to 15.5 kV.

Both combinations are suitable for universal use in 3/(N) AC, AC/DC and DC systems. AC systems may include extensive DC supplied loads, such as converters or thyristor-controlled DC drives. Drive systems including a converter and a motor in medium voltage systems can be monitored.

- When the AGH675S-7 is connected in the mid-point of the converter DC intermediate circuit, a maximum of  $\pm 7.2$  kV against PE may occur.
- When the two coupling devices AGH675S-7MV15 are connected in the mid-point of the converter DC intermediate circuit, a maximum of  $\pm 15.5$  kV against PE may occur.

The device automatically adapts itself to the existing system leakage capacitance. The IRDH275BM-7 can be used in combination with a control and indication panel, e.g. PRC1470 version 2 or higher, on the BMS (BMS = Bender Measuring Device Interface) bus.

## 3.3 Function

The combination ISOMETER® IRDH275BM-7 and coupling device AGH675S-7 or two coupling devices AGH675S-7MV15 is operated between the unearthed system (IT system) and the protective conductor (PE).

The response values and other function parameters are set via the function keys. The parameters are indicated on the LC display and are stored in a non-volatile memory (EEPROM) after the setting is completed.

A microprocessor-controlled pulsating AC measuring voltage is superimposed on the IT system to be monitored (**AMPPlus** measuring principle\*). The measuring cycle consists of positive and negative pulses of the same amplitude. The period of these pulses depends on the respective system leakage capacitances and the insulation resistances of the IT system to be monitored.

An insulation fault between the IT system and earth closes the measuring circuit. From the measured current value, the microprocessor calculates the insulation resistance which is indicated on the LC display or the external k $\Omega$  measuring instrument.

The measuring time  $t_{an}$  is determined by the system leakage capacitances, the insulation resistance, and the system-related interference disturbances. System leakage capacitances do not influence the measuring accuracy. When virtually no disturbances are caused by the operation of converters, the measuring process takes about five minutes.

If the reading is below the selected response values Alarm 1/Alarm 2, the associated alarm relays respond and the alarm LEDs "Alarm 1/2" light up and the measuring value is indicated on the LC display (in the event of DC insulation faults, the faulty supply line is indicated). If the terminals R1/R2 are bridged (external RESET button [NC contact] or wire bridge), the fault indication will be stored. Pressing the RESET button, resets the insulation fault message, provided that the currently displayed insulation resistance is at least 25 % above the actual response value when the reset is carried out. The fault memory behaviour can also be set in the "ISO SETUP" menu, by selecting the sub menu Memory: on/off.

The connections for an external k $\Omega$  display supplied by the current output 0(4)...20 mA at M+/M- are galvanically isolated.



\*) **AMPPlus** measuring principle "adaptive measuring pulse", a measuring principle developed by Bender (European Patent: EP 0 654 673 B1).

## Self test

A self test can be carried out manually using the TEST button or automatically. In order to guarantee high functional reliability, the ISOMETER® IRDH275BM-7 provides comprehensive self test functions. After switching the supply voltage on, all internal measuring functions, the components of the process control such as data and parameter memory as well as the earth connections are checked using the self test functions. The progress of the self test is indicated on the LC display by a bar graph. Depending on the conditions in the IT system to be monitored, the self test is running for 15...20 seconds, then the message "Test ok!" appears on the LC display for approximately 2 seconds. Then the device returns to the standard mode and the current measuring value is displayed after the expiry of the measuring time.

When a fault is found at the terminals  and KE, the message "!Error!" appears on the LC display, the system fault LED lights up, the relay K2 (21-22-24) switches and the respective fault message (see table) is indicated. If such a system fault occurs, a self test is started again every minute. If no more malfunction is detected, the fault message is deleted automatically and the system fault LED extinguishes.

During operation, the self test function can be started by pressing the TEST button (internal or external). The self test can also be started automatically every hour or every 24 hours by selecting "ISO ADVANCED: Autotest" menu. The alarm relays Alarm1/2 only switch after starting the self test function by pressing the TEST button, that means if an automatic self test has been selected, the alarm relays do not switch.

Error message	Meaning	Steps to be taken
Connection PE?	No low-resistance connection of the terminals  and KE to earth (PE)	<ol style="list-style-type: none"> <li>1. Check wiring of terminal  and KE to earth (PE)</li> <li>2. Press TEST button</li> <li>3. Switch the supply voltage off and on</li> </ol>
Device error x	Internal device error	<ol style="list-style-type: none"> <li>1. Press TEST button</li> <li>2. Switch the supply voltage off and on</li> <li>3. Contact Bender</li> </ol>



*If the on/off switching of the supply voltage is not possible for technical reasons, a RESET of the process control can be carried out by pressing the "ESC", "RESET" and "MENU" key.*

### Current output for external measuring instrument

The current output of the ISOMETER® provides 0(4)...20 mA. The current output is galvanically isolated from the device electronics and the RS-485 interface. The ISO SETUP menu, on page 31, allows to switch over between 0...20 mA and 4...20 mA.

### Real-time clock

The real-time clock serves as a time base for the memory and self test functions. At first, the correct time and date must be set in the menu "ISO ADVANCED". If time and date are not set, a „C“ (clock) is flashing in the standard display. In the event of a supply voltage failure, time and date will be stored for at least thirty days.

If the 24 V test is activated in the "ISO ADVANCED" menu, a special time of day can be selected for the execution of the self test in the menu "TEST: 12:00". Then a self test will be started automatically once a day exactly at the preset time. If the 1 h auto test has been selected, the self test is automatically carried out every full hour.

**Function input F1/F2 to switch over to the standby mode**

When the input terminals F1/F2 are bridged, the measuring function is stopped and the message "STANDBY" appears on the display. The currently measured value is blanked and the value  $> 10 \text{ M}\Omega$  is indicated. The alarm relays and alarm LEDs no longer provide alarm messages. After opening the function input F1/F2, a completely new measuring cycle for insulation monitoring is started.

## 4. Installation and connection

### 4.1 Installation of the coupling device AGH675S-7...



**DANGER**

---

***Danger of electric shock!***

*The coupling device is operated with voltages above 1000 V, which can be life-threatening in case of direct contact. Make sure that only electrically skilled persons work on or with the device. Read the operating manual of the coupling device carefully.*

---

- For operation the coupling devices have to be installed into a "closed electrical operating area", refer to IEC 61800-5-1:2003
- The coupling device is to be installed in a place where the pollution degree to be expected is  $\leq 2$ , refer to IEC 61800-5-1: 2003, subclause 4.2.6.2.2
- An "Enclosure suitable for high voltage areas" has to be selected for installation, refer to IEC 61800-5-1: 2003
- The high voltage connection cable must not be directly routed on conductive surfaces that are connected to earth. This avoids partial discharges and prevents damage to the insulation of the high voltage cable between the AGH and the system to be monitored!  
Either additional insulation layers are required or a clearance of  $\geq 10$  cm between the cable and the conductive surfaces has to be provided.



## 4.2 Wiring diagram

Connect the terminals A1/+ and A2/- to the supply voltage  $U_s$  in accordance with IEC 60364-4-43. The connections to the supply voltage shall be provided with protective devices to afford protection in the event of a short circuit (a 6 A fuse is recommended).

For UL and CSA applications, the use of 5 A fuses is mandatory.

Only one ISOMETER® may be connected to an external TEST or RESET button. The TEST and RESET button for collective testing of several insulation monitoring devices must not be connected in parallel.

External coupling device connected via the terminal AK cannot be switched off via the internal coupling relays.

## Wiring diagram AGH675S-7

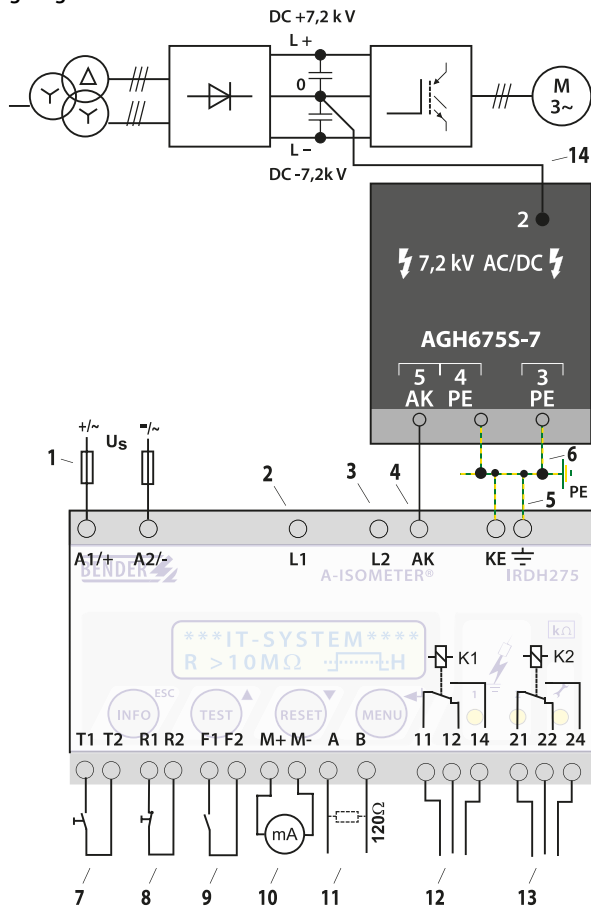

## Wiring diagram AGH675S-7MV15

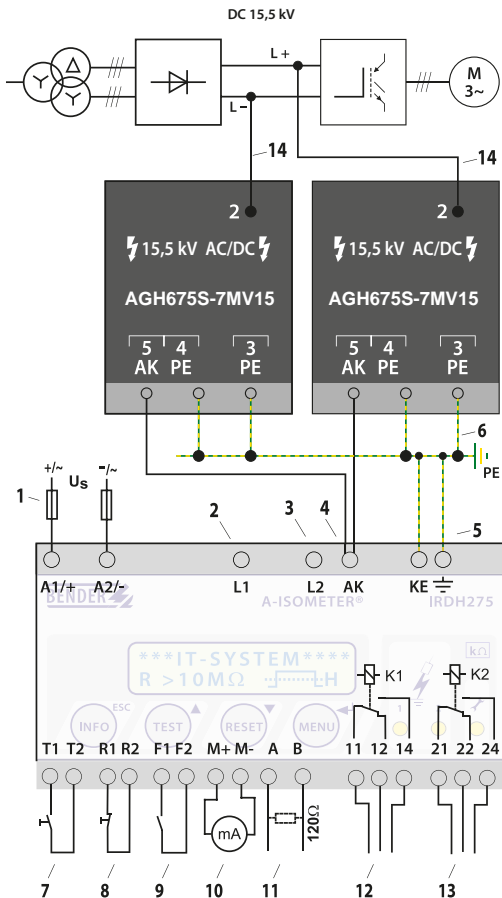

**Legend to wiring diagram:**

- 1 Supply voltage  $U_s$  (see nameplate) via 6 A fuse
- 2, 3 Terminals L1, L2 are not connected!
- 4 Connection to the coupling device AGH675S-7 or the two coupling devices AGH675S-7MV15:  
connect terminal AK to terminal(s) 5 of the coupling device AGH675S-7 (or the two coupling devices AGH675S-7MV15),  
connection with standard low-voltage cable,  
maximum voltage at terminal 5: 200 V
- 5 Separate connection of  and KE to PE
- 6 Separate connection of the terminals 3 and 4 of the AGH675S-7 or AGH675S-7MV15 to PE
- 7 External TEST button (NO contact)
- 8 External RESET button (NC contact or wire jumper),  
when the terminals are open, the fault message will not be stored
- 9 STANDBY by means of the function input F1, F2:  
When the contact is closed, insulation measurement does not take place.
- 10 Current output, galvanically separated:  
0...20 mA or 4...20 mA
- 11 Serial interface RS-485 (termination 120  $\Omega$  resistor)
- 12 Alarm relay 1; changeover contacts provided
- 13 Alarm relay 2 (system fault relay); changeover contacts provided
- 14 Connection of the coupling device AGH675S-7 to the converter:  
connect the high voltage cable encapsulated on one end to the mid-point of the DC intermediate circuit.  
Connection of the two coupling devices AGH675S-7MV15 to the converter:  
connect the high voltage cable encapsulated on L+ and L-.



*The wiring diagram before is to be taken by way of example.*

## 5. Operation and setting

### 5.1 Operating features and displays IRDH275BM-7

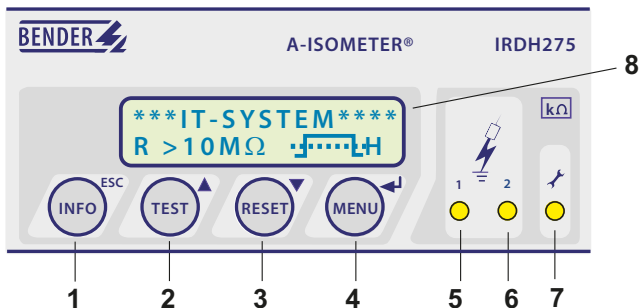

- 1 INFO key: to query standard information /  
ESC key: back to the menu function, confirmation parameter change
- 2 TEST button: to call up the self test/  
Up key: parameter change, moving up in the menu
- 3 RESET button: to delete insulation fault alarms  
Down key: parameter change, moving down in the menu
- 4 MENU key: to activate the menu system / Enter key: confirmation parameter change
- 5 Alarm LED 1 lights: insulation fault, first warning level reached
- 6 Alarm LED 2 lights: insulation fault, second warning level reached
- 7 System fault LED lights: IRDH275 defective
- 8 Two-line display for standard and menu mode

A detailed description of the operating elements is given on the following pages.

### 5.1.1 Display in the standard mode



- 1 Indication of the insulation resistance in kΩ
- 2 Additional information about the insulation resistance:
  - "+" = insulation fault at L+
  - "-" = insulation fault at L-
  - "s" = new measurement has started
- 3  = polarity of the measuring pulse
  - . = valid bus communication signals
  - H = new entry in the memory data base
  - C = flashing, clock is to be set
- 4 Messages:
  - Insulation fault
  - Connection PE?
  - Device error x
  - \*\*\*\*\*STAND BY\*\*\*\*\*

### 5.1.2 Display in the menu mode

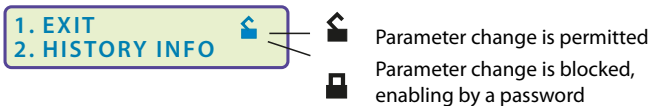

### 5.1.3 Function keys

Two functions are assigned to each function key. In addition to the basic function marked with a circle, all the keys allow navigation within the menu.



Pressing the INFO key provides the following information without opening the menu:

- Device name, firmware version
- Response values Alarm 1 and Alarm 2
- Setup status (for details refer to the table of the status numbers on page 67)
- COM-Setup (own bus address)

Please have the details above on hand if you have a problem and if you contact Bender for technical questions.



Activating the TEST button starts the ISOMETER® self test.

Pressing the RESET button resets insulation and fault alarm messages stored in the ISOMETER®. The memory function is only

available after activating the fault memory in the ISO SETUP menu or after bridging the terminals R1/R2. Furthermore, the ISOMETER® can only be reset when the present insulation value is 25 % higher than the set response value.

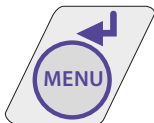

The menu system is called up by pressing the MENU key.



For controlling the menu system, the arrow keys, the ENTER key and the ESC key are used:



Arrow up key:  
Moving up in the menu, increasing a parameter



Arrow down key:  
Moving down in the menu, reducing a parameter



ENTER key  
Selecting a menu item or sub menu item, confirming or storing a parameter change and going back to the associated sub menu item or going to the next input area.



ESC key:  
Returning from a sub menu to the previous menu.

If you do not exit the menu, the device automatically returns to the standard mode again after approximately five minutes.

For the sake of clarity, the following symbols are used for the functions ENTER, UP/DOWN and ESCAPE in the menu diagrams of this operating manual:



## 5.2 Menu structure and menu mode

### Switchover to the menu mode

After pressing the MENU key, you can change from the standard mode to the menu mode. From the menu mode you can link to the different sub menus.

### Navigation within the menu

Select the desired menu item using the UP/DOWN keys. The selected menu item is indicated by a flashing cursor. Press the ENTER key to open the associated sub menu.

Use the UP/DOWN keys again to select the desired parameters. Move the cursor to the edit field by pressing the ENTER key.

If you have reached the end of the main menu list, it will be indicated by the "Arrow UP" symbol.

### Changing the parameters

When password protection is activated, indicated by the symbol "padlock closed" , the first thing to enter is the correct password before the parameters can be changed using the UP/DOWN keys. Entering the correct password once allows all parameters to be changed as long as you do not leave the menu.

Changing the parameter usually has an immediate effect on the measuring and alarm functions. The changed parameter is stored in a volatile memory by pressing the ENTER or ESC key after returning to the sub menu (flashing cursor in column 1). During menu operations, all measuring and alarm functions carry on working as usual in the background.

### Changing from the menu mode to the standard mode

Pressing the ESC key allows fast changing from the menu mode to the standard mode. Thus, the menu item "EXIT" need not to be activated. Automatic switchover from the menu mode to the standard mode takes place when no key is pressed for approximately five minutes in a main or sub menu.

## 5.2.1 Diagram menu structure

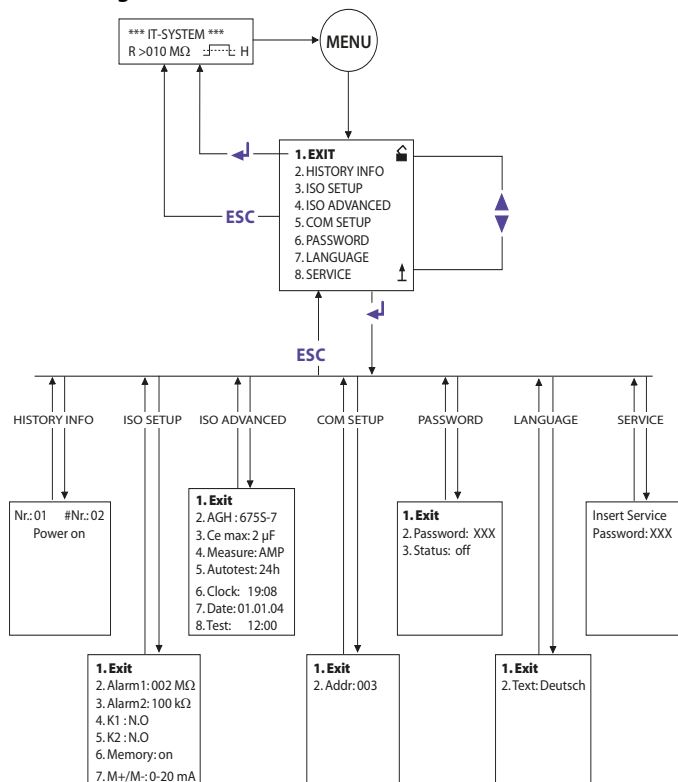

## 5.3 Menu HISTORY INFO

99 events with date and time stamp can be stored in the memory database. The database is designed as a ring memory, i.e. the eldest entry is overwritten. Data is written into a non-volatile memory and therefore provides protection against voltage failure.

### Data record Event

- 1 Switch the supply voltage on
- 2 Lowest measured insulation value
- 3...99 Response value Alarm 1 released
- 3...99 Response value Alarm 1 cleared
- 3...99 Response value Alarm 2 released
- 3...99 Response value Alarm 2 cleared
- 3...99 Error system connection released
- 3...99 Error system connection cleared
- 3...99 Error PE connection released
- 3...99 Error PE connection cleared
- 3...99 Device error released
- 3...99 Device error cleared
- 3...99 System reset (watchdog)

### Display indication

- Power On
- Rmin
- Alarm1
- Alarm1
- Alarm2
- Alarm2
- System connection?
- System connection?
- PE connection?
- PE connection?
- Device error
- Device error
- System reset

Before storing the events with the actual date and time stamp, set the real-time clock in the ISO ADVANCED menu (refer to page 44).

The following function keys are provided to query data from the "HISTORY INFO" menu: the UP/DOWN keys to change the data record number, the ENTER key to change from the data record number to the menu item "Clear all:on" to delete the memory storage, and the ESC key to leave the menu.

A new entry into the memory is signalled with an "H" on the display in the standard mode. The "H" will be deleted as soon as the "HISTORY INFO" menu is called up.



## 5.4 Menu ISO SETUP: Setting of the basic ISOMETER® functions

All alarm functions such as Alarm 1 and Alarm 2 (prewarning and main alarm), the operating principle of the alarm relays K1 and K2 (N.O = N/O operation, N.C = N/C operation), the fault storage behaviour and a selection of two current output ranges are set in this menu.

### 5.4.1 Response values Alarm 1 and Alarm 2

The response values Alarm 1 and Alarm 2 are selected with the UP/DOWN keys and stored with the ENTER key.

## 5.4.2 Operating principle of the alarm relays

K1/K2 are factory set to N.O Test, that means N/O operation. When the supplement "Test" has been selected, the alarm relays switch over during a manual self test.

If, for any reason, the alarm relays may not switch over during a manual self test, the settings N.C or N.O are to be selected.

- K1: N.C Test = N/C operation contacts 11-12-14, with relay test (the alarm relay is energized during normal operation)
- K1: N.O Test = N/O operation contacts 11-12-14, with relay test (the alarm relay is deenergized during normal operation)
- K1: N.C = N/C operation contacts 11-12-14, without relay test (the alarm relay is energized during normal operation)
- K1: N.O = N/O operation contacts 11-12-14, without relay test (the alarm relay is deenergized during normal operation)
- K1: Flash = Flashing function contacts 11-12-14 (the alarm relay and the LED flash in the event of an alarm message, approximately 0.5 Hz)
- K2: N.C Test = N/C operation contacts 21-22-24, with relay test (the alarm relay is energized during normal operation)
- K2: N.O Test = N/O operation contacts 21-22-24, with relay test (the alarm relay is deenergized during normal operation)
- K2 : N.C = N/C operation contacts 21-22-24, without relay test (the alarm relay is energized during normal operation)
- K2 : N.O = N/O operation contacts 21-22-24, without relay test (the alarm relay is deenergized during normal operation)
- K2 : Flash = Flashing function contacts 21-22-24 (the alarm relay and the LED flash in the event of an alarm message, approximately 0.5 Hz)

## Diagram ISO SETUP

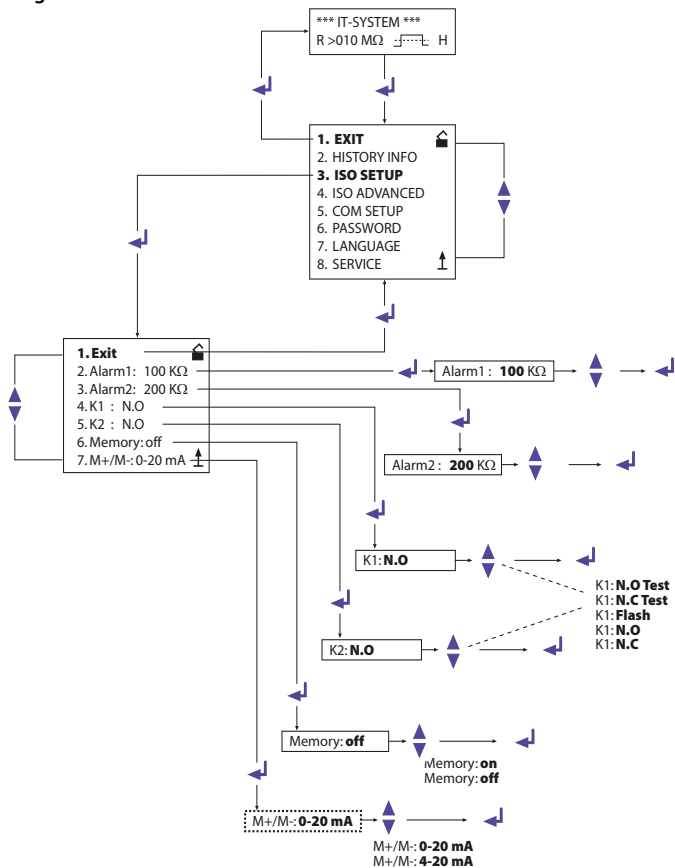





*During the automatic self test, the alarm relays are not switched over.*



*When a system fault occurs at the ISOMETER®, the relay K2 will automatically be activated as a system fault relay.*

### 5.4.3 Memory setting (on/off)

- Memory: on = Fault memory is activated  
The device must be reset with the RESET button after clearing the fault.
- Memory: off = Fault memory deactivated (factory setting)

### 5.4.4 Current output for external measuring instruments

Factory setting: 0...20 mA

The current output of the IRDH275BM-7 can be set to "0...20 mA" or "4...20 mA" via the menu point "M+/M-:". The maximum load is 500 Ω.

Function 0...20 mA:

$R_F$  = insulation fault,

$I$  = current in mA

$$R_F = \frac{20 \text{ mA} \times 2800 \text{ k}\Omega}{I} - 2800 \text{ k}\Omega$$

Function 4...20 mA:

$R_F$  = insulation fault,

$I$  = current in mA

$$R_F = \frac{16 \text{ mA} \times 2800 \text{ k}\Omega}{I - 4 \text{ mA}} - 2800 \text{ k}\Omega$$

The associated characteristic curves are illustrated on page 65.

## 5.5 Menu ISO ADVANCED: Setting of the extended functions

### 5.5.1 Coupling devices AGH: 675S-7...

The ISOMETER® is connected to the AGH675S-7 by connecting the terminal AK to terminal 5. The nominal operating range is extended to AC 0...7.2 kV (AGH475S-7) or AC 0...15.5 kV (two AGH475S-7MV). When terminal 2 will be connected to the midpoint of the DC intermediate circuit, a voltage of 14.4 kV is permitted.

### 5.5.2 Adaptation to the system leakage capacitance Cemax

This menu allows to adapt the ISOMETER® to the maximum system leakage capacitance (2 or 5  $\mu\text{F}$ ). Please note that the basic measuring time will take no longer than five minutes when virtually no converter-related disturbances are present.

Factory setting = 2  $\mu\text{F}$ .

### 5.5.3 Measuring principle (Measure: AMP)

The AMP measuring principle is factory set.

### 5.5.4 Setting the repetition time for automatic self tests (Autotest: 24h)

The time for the repetition of automatic self tests can either be set to 1 hour or to 24 hours or can be deactivated.

Factory setting = 24 h

### 5.5.5 Setting the real-time clock (Clock)

The setting of the real-time clock is the time base for the memory and for the automatic self test. In case of failure of the supply voltage, the real-time clock keeps running for approximately 30 days. When the device will be switched on after this period, a flashing "C" appears on the display and the clock has to be set again.

### 5.5.6 Setting the date (Date)

As well as the time, the date is required for the memory, too. In the event of power supply failure, the date function is not influenced for at least 30 days. If the device is switched on again after this period, a new setting of date and time of the real-time clock is required.

### 5.5.7 Specifying the starting time of the automatic self test (Test) (IRDH275B)

If the 24h self test is activated in the ISO ADVANCED menu, it is possible to set the time (hour) when the self test is to be carried out by means of the "TEST: 12:00" sub menu. Then the self test is automatically carried out once a day at a given time. If the 1 hour auto test has been selected, the self test will be carried out at every full hour.

## 5.5.8 Diagram ISO ADVANCED

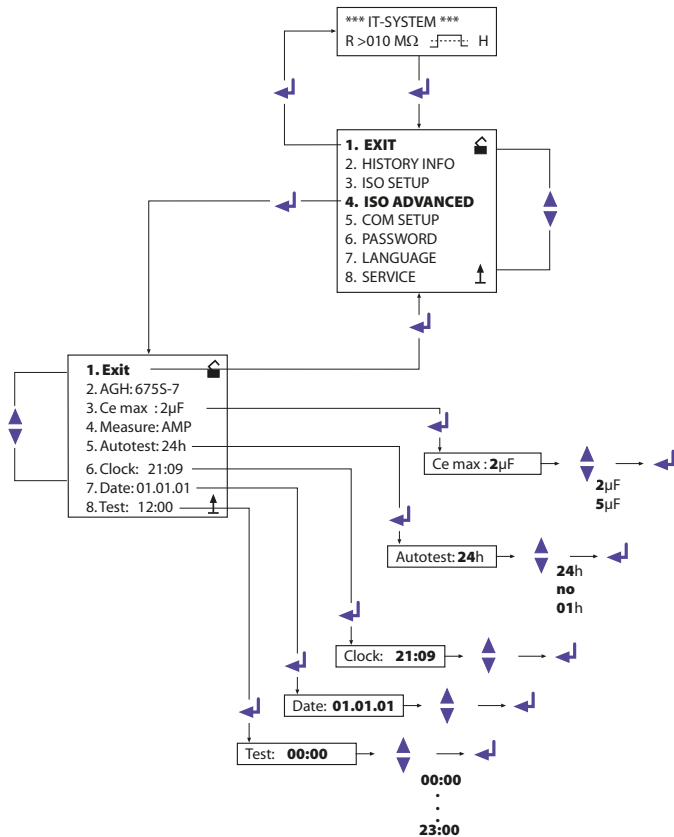

## 5.6 Menu COM SETUP: Setting the BMS interface

### 5.6.1 Bus address „Addr:“

This menu item is used to set the BMS bus address of the ISOMETER®. Since there are several ISOMETERs in one system, take care that the bus address is not assigned twice.

The device is factory set to address 3 and hence acts as a slave.



*If several ISOMETER®s are operated on one BMS bus, the addresses of other ISOMETER®s must be assigned one after the other, since only one device may represent the Master.*

## 5.6.2 Diagram COM SETUP

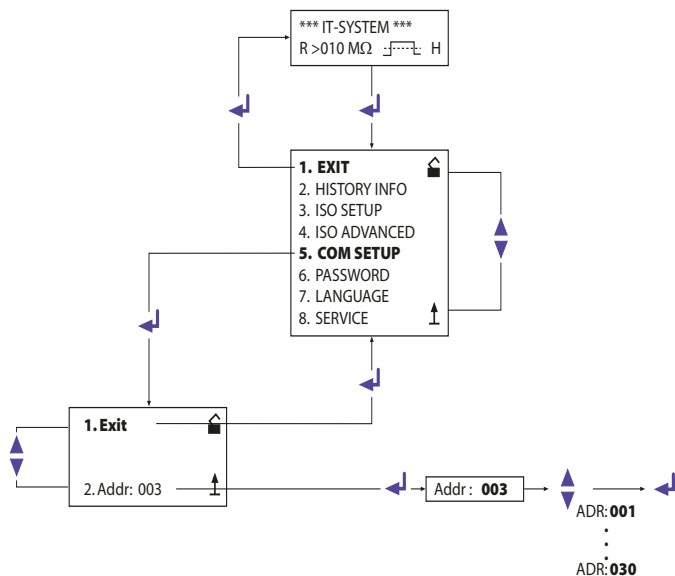

## 5.7 Menu PASSWORD

### 5.7.1 Activating and setting the password

This menu can be used to activate a "Password" query. This protects the ISOMETER® against unauthorized settings and modifications. The desired password (menu item 2. Password: xxx) can be set with the UP/DOWN keys and confirmed with the ENTER key. The password can be activated in the menu item "3. Status: on" by clicking the ENTER key. The basic setting is "3. Status: off", that means that the password is deactivated.

## 5.7.2 Diagram PASSWORD

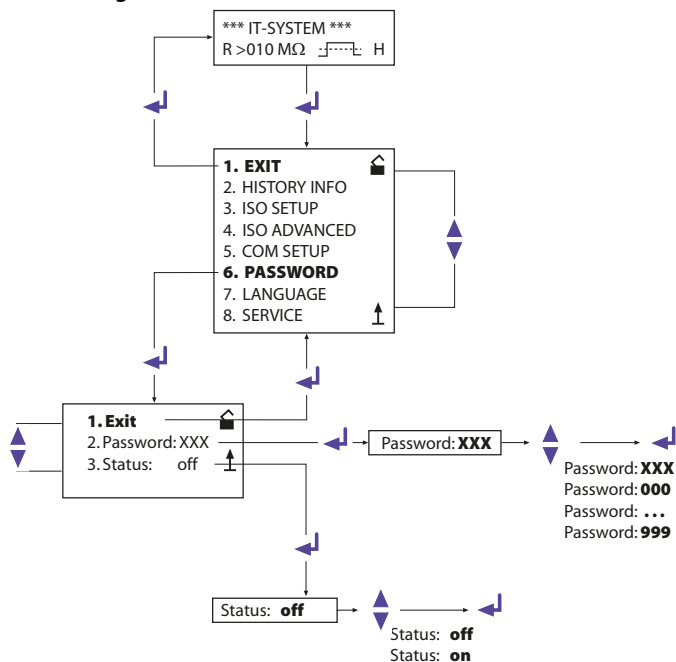



## 5.8 Menu LANGUAGE

### 5.8.1 Setting the national language

The menu item "Language" allows fault messages of the ISOMETER® to be set to different languages. There is the choice of German and English.

The device menu is not influenced by the language selection.

### 5.8.2 Diagram Language

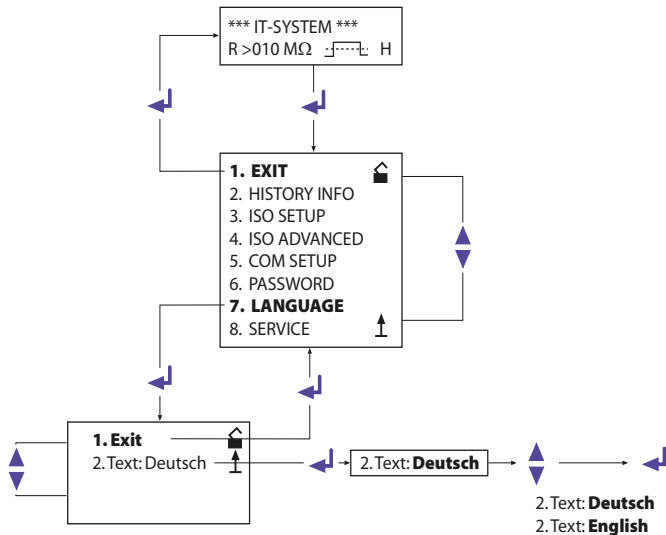

## 5.9 Menu SERVICE

This menu item is provided for the Bender service personnel and is protected by a password against erroneous settings. It is intended to provide fast fault clearance by qualified experts in the event of a device error.

## 5.10 Parameterization via Internet

The parameters of the ISOMETER® indicated below can be checked and set from a remote place of use by using a personal computer. In addition, a browser (viewing program for Internet application) and our protocol converter FTC470XET (BMS <==> Ethernet/TCP/IP) are required.

Remote setting is possible for:

- Response value Alarm 1 (100...10,000 k $\Omega$ )
- Response value Alarm 2 (100...10,000 k $\Omega$ )
- Operating principle alarm relay K1 (e.g. N/O operation)
- Operating principle alarm relay K2 (e.g. N/O operation)
- Current output ranges for external measuring instruments (0/4...20 mA)
- Maximum system leakage capacitance (2  $\mu$ F or 5  $\mu$ F)
- Time for repetition of the automatic self test (off/ 1 h/ 24 h)
- Starting time of the automatic self test (0.00...23.00 h)
- Language of the alarm messages to be displayed (D, GB)
- Setting the fault memory to ON or OFF

## 6. Serial interfaces

### 6.1 RS-485 interface with BMS protocol

The RS-485 interface which is galvanically isolated from the device electronics and current output serves as a physical transmission medium for the BMS protocol. If several ISOMETER®s or other bus-capable devices are interconnected in a network via the BMS bus, the BMS bus must be terminated at both ends with a  $120\ \Omega$  resistor.

An RS-485 network that is not terminated, is likely to get instable and may result in malfunctions. Only the first and the last device in one line may be terminated. Devices in between must not be terminated with  $120\ \Omega$ . Hence, stub feeders in the network must not be terminated. The length of the stub feeders is restricted to 1 meter.

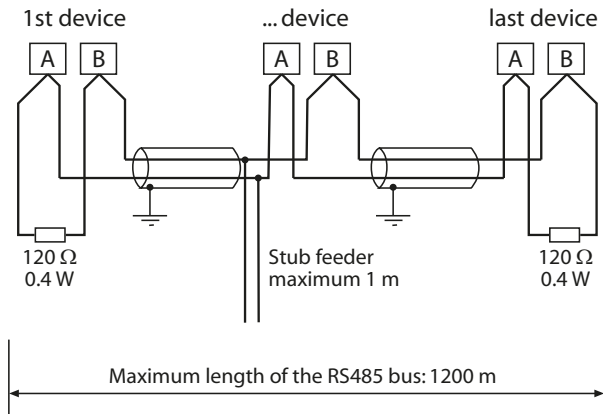

## 6.2 Topology RS-485 network

The optimum topology for the RS-485 network is a daisy-chain connection. In this connection, device 1 is connected to device 2, device 2 to device 3, device 3 to device n etc. The RS-485 network represents a continuous path without branches.

### 6.2.1 Correct arrangement

Three examples for correct arrangement:

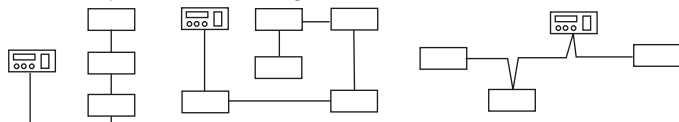

### 6.2.2 Wrong arrangement

Three examples for wrong arrangement:

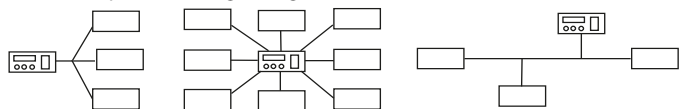

### 6.2.3 Wiring

A suitable type of cable for the wiring of the RS-485 network is:

screened cable, core diameter  $\geq 0.6$  mm

(e.g. J-Y(ST)Y 2x0.6), screen on one side connected to earth (PE).

Connection to the terminals A and B.

The number of bus nodes is restricted to 32 devices. When more devices are to be connected, Bender recommends to use an RS-485 repeater DI1.

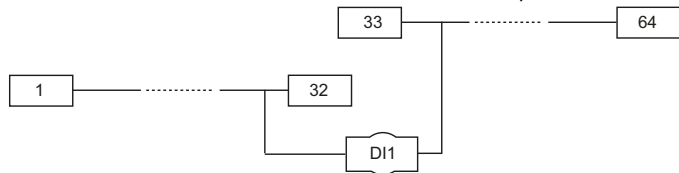

## 6.3 BMS protocol

This protocol is an essential part of the Bender Measuring Device Interface. Data transmission generally makes use of ASCII characters.

Interface data are:

- Baud rate: 9600 baud
- transmission: 1 start bit, 7 data bits, 1 parity bit, 1 stop bit (1, 7, E, 1)
- Parity: even
- Checksum: sum of all transmitted bytes = 0 (without CR and LF)

The BMS bus protocol works according to the MASTER-SLAVE principle. That means that one device represents the MASTER while all other bus nodes are SLAVES. It is important that only one MASTER is present in each network. All bus nodes are identified by a unique address. The MASTER scans all other devices on the bus cyclically, listens to their signals and then carries out specific commands. Bus address 1 must be assigned to the Master, thus to one of the IRDH275B devices.

### 6.3.1 BMS Master

A Master can query all warning and operating messages from a slave.

If the bus address 1 has been selected for one IRDH275B, this device automatically represents the Master, that means that all addresses between 1 and 150 are cyclically scanned via the BMS bus for alarm and operating messages. If the Master receives no answer from five subsequent addresses, the scanning cycle is started again. If the Master recognizes incorrect answers from a slave, the fault message "Fault RS-485" is issued by the Master.

**Fault RS485**  
**Rs = 011 k $\Omega$**   **H**

Faults may be caused when:

- addresses are assigned twice
- a second master exists on the BMS bus
- interference signals occur on the bus lines
- a defective device is connected to the bus
- terminating resistors are not activated

### 6.3.2 BMS Slave

All IRDH275B are factory set to slave mode (address 3). In a BMS network, one address must be selected from the address range 2...30 for each slave. There may be no gaps of more than five subsequent addresses, so that all slaves can be scanned by the Master. For IRDH275B a BMS address can be selected from the address range 1...30. When assigning the addresses, also other devices such as the EDS47x-12 must be considered.

The correct reception of BMS data is indicated by a flashing point on the display on the right of the measuring pulse indication.



If no flashing point appears, it may be attributed to the following:

- no Master available in the network
- more than one Master available in the network
- RS-485 interface (terminal A/B) not connected or reversed

The following table gives an overview about essential alarm messages and the assignment of the messages indicated on the display or operator panels, e.g. PRC1470.

Message	Channel	Meaning
Insulation Fault	1	Insulation resistance < setting Alarm 1
Insulation Fault	2	Insulation resistance < setting Alarm 2
Connection PE	4	Connection error  /KE against PE conductor
Device error	5	Internal device error

The BMS function is completely available in the standby mode (Stand-by: F1/F2).

### 6.3.3 Commissioning of an RS-485 network with BMS protocol

- Connect the terminals A and B of all bus nodes in one line
- Switch the terminating resistors on at the beginning and end of the RS-485 network or in case of devices without a terminating switch, at the end of the bus, connect a 120  $\Omega$  resistor to the terminals A and B.
- Switch the supply voltage  $U_S$  on.
- Determine one IRDH275B as the Master and assign address 1.
- Assign the addresses (2...30) subsequently to all other IRDH275B devices and other bus nodes (see table below).
- Check whether a flashing point appears on all devices (BMS commands are being received).

**BMS-bus address ranges**

Addresses*	Device	Meaning
0		There is no device with address 0! Information sent to address 0 applies to all devices connected to the interface (broadcast)
1	PRC1470	Control and indicating device
1...30	IRDH275B/ 375B/575	Insulation monitoring device
1...30	FTC470...	Protocol converter
2...30	EDS47x-12	Insulation fault evaluators (localisation)
31...60	SMO480-12	Signal converter relay
61...90	EDS47xE-12	Insulation fault evaluators (localisation)
111...119	PGH47x	Test device for insulation fault location
121...150	PGH47xE	Test device for insulation fault location

***Malfunctions due to wrong address assignment!***

*Assigning wrong addresses to external devices may cause malfunctions.*

*Assign the addresses in a way that there are no gaps of more than five subsequent addresses (1...30, 31...60, 61...90, 111...119 and 121...151).*



## 7. Technical data IRDH275BM-7 with AGH675S-7...

### 7.1 Data in tabular IRDH275BM-7

#### Insulation coordination acc. to IEC 60664-1

Rated voltage .....	AC 800 V
Rated impulse voltage/pollution degree .....	8 kV/3

#### Voltage ranges

Nominal voltage range $U_n$ .....	via AGH675S-7 ...
Supply voltage $U_s$ (refer to nameplate for other values) .....	DC 19.2 ... 72 V
Power consumption .....	≤ 14 VA

#### Response values

Response value $R_{an1}$ (Alarm 1) .....	100 kΩ ... 10 MΩ
Response value $R_{an2}$ (Alarm 2) .....	100 kΩ ... 10 MΩ
Relative percentage error 100 ... 500 kΩ .....	± 100 kΩ
Relative percentage error 500 kΩ ... 10 MΩ .....	0 % ... +20 %
Response time $t_{an}$ .....	≤ 5 min
Hysteresis .....	25 %

#### Measuring circuit

Measuring voltage $U_m$ .....	≤ 50 V
Measuring current $I_m$ (at $R_F = 0 \Omega$ ) .....	≤ 21 μA
Internal DC resistance $R_i$ .....	≥ 2.4 MΩ
Internal impedance $Z_i$ at 50 Hz .....	≥ 2.4 MΩ
Permissible extraneous DC voltage $U_{fg}$ .....	with AGH675S-7 ...
Permissible system leakage capacitance $C_e$ .....	≤ 5 μF
Factory setting .....	2 μF

## Displays

Display, illuminated .....	two-line display
Characters (number of characters) .....	2 x 16
Display range, measuring value .....	50 k $\Omega$ . . . 10 M $\Omega$
Relative percentage error 50 . . . 500 k $\Omega$ .....	$\pm 50$ %
Relative percentage error 500 k $\Omega$ . . . 10 M $\Omega$ .....	$\pm 10$ %

## Outputs/inputs

TEST/RESET button .....	internal/external
Cable length TEST/RESET button external .....	$\leq 10$ m
Current output for measuring instrument SKMP (scale centre point = 1.2 M $\Omega$ ): .....	
Current output (load) .....	20 mA ( $\leq 500$ $\Omega$ )
Accuracy current output (100 k $\Omega$ . . . 10 M $\Omega$ ) .....	$\pm 10$ %, $\pm 100$ k $\Omega$

## Serial interface

Interface/Protocol IRDH275B .....	RS-485/BMS
Connection .....	terminals A/B
Cable length .....	$\leq 1,200$ m
Recommended cable (screened, screen on one side connected to PE) .....	J-Y(St)Y 2 x 0.6
Terminating resistor .....	120 $\Omega$ (0.5 W)
Device address, BMS bus .....	1 . . . 30 (factory setting = 3)

## Switching components

Switching components .....	2 changeover contacts: K1 (Alarm 1), K2 (Alarm 2, system fault)
Operating principle K1, K2 (Alarm 1, Alarm 2) .....	N/O or N/C operation
Factory setting (Alarm 1/Alarm 2) .....	N/O operation
Electrical endurance .....	12,000 switching operations
Contact class .....	IIB (IEC 60255-23)
Rated contact voltage .....	AC 250 V/DC 300 V
Making capacity .....	AC/DC 5 A
Breaking capacity .....	2 A, AC 230 V, $\cos \phi = 0.4$
.....	0.2 A, DC 220 V, L/R = 0.04 s
Minimum contact current at DC 24 V .....	$\geq 2$ mA (50 mW)

## Environment/EMC

EMC immunity .....	acc. to EN 61326
EMC emission .....	acc. to EN 61326
Shock resistance IEC 60068-2-27 (device in operation) .....	15 g/11 ms
Bumping IEC 60068-2-29 (during transport) .....	40 g/6 ms
Vibration resistance IEC 60068-2-6 (device in operation) .....	1 g/10 ... 150 Hz
Vibration resistance IEC 60068-2-6 (during transport) .....	2 g/10 ... 150 Hz
Ambient temperature (during operation) .....	-10 ... +55 °C
Storage temperature range .....	-40 ... +70 °C
Climatic class acc. to IEC 60721-3-3 .....	3K5

## Connection

Connection .....	screw terminals
Connection, rigid, flexible .....	0.2 ... 4 mm <sup>2</sup> /0.2 ... 2.5 mm <sup>2</sup>
Connection, flexible with connector sleeve, without/with plastic sleeve .....	0.25 ... 2.5 mm <sup>2</sup>
Conductor sizes .....	AWG 24 ... 12

## General Data

Operating mode .....	continuous operation
Mounting .....	as indicated on the display
Protection class, internal components (DIN EN 60529) .....	IP30
Protection class, terminals (DIN EN 60529) .....	IP20
Type of enclosure .....	X112, free from halogen
DIN rail mounting .....	IEC 60715
Flammability class .....	UL94 V-0
Tightening torque .....	0.5 Nm
Weight approx. ....	510 g

## 7.2 Standards and approvals

### Standards

The ISOMETER® was designed under consideration of the following standard:

- IEC 61557-8: 2007 + Corrigendum 2007-05
- IEC 61326: 2002-02
- DIN EN 61557-8: 2007-12
- EN 61557-8: 2007
- EN 61326-2-4: 2006-06 Ed. 1.0
- DIN EN 60664-1: 2008-01
- DIN EN 60664-3: 2003-09
- ASTM F1669M-96: 2007
- ASTM F1207M-96: 2007

Subject to change! The specified standards take into account the edition valid until 07.2018 unless otherwise indicated.

### Approvals



IRDH275BM-7 and AGH675S-7:



## 7.3 Data in tabular AGH675S-7

### Insulation coordination in consideration of IEC 61800-5-1:2003

Rated voltage ..... AC 7.2 V

### Voltage test in consideration of IEC 61800-5-1:2003

Type test:

Rated impulse voltage (basic insulation) ..... 40 kV

AC voltage test (basic insulation) ..... 20 kV

Partial discharge test ..... 14 kV

Routine test:

AC voltage test ..... 40 kV

### Voltage ranges

Nominal voltage range  $U_n$  ..... AC, 3(N)AC, DC 0...7.2 kV

Nominal frequency  $f_n$  ..... 0...460 Hz

### Environment/EMC

Operating temperature (normal operation) ..... -10...+60 °C

Operating temperature (continuous operation with asymmetrical earth fault) ..... -10...+55 °C

Classification of climatic conditions acc. to IEC 60721:

Stationary use (IEC 60721-3-3) ..... 3K5 (no condensation, no formation of ice)

Transport (IEC 60721-3-2) ..... 2K3 (no condensation, no formation of ice)

Long-term storage (IEC 60721-3-1) ..... 1K4 (no condensation, no formation of ice)

Classification of mechanical conditions acc. to IEC 60721:

Stationary use (IEC 60721-3-3) ..... 3M4 (3M7 Y shaft)

Transport (IEC 60721-3-2) ..... 2M2

Long-term storage (IEC 60721-3-1) ..... 1M3

### Connection

Connection terminal 2 (medium voltage) ..... high-voltage cable (encapsulated on the device side)

Connection, flexible with ring terminal ..... M4

Connection terminal 3, 4, 5 ..... screw-type terminals

Connection, rigid, flexible ..... 0.2...4 mm<sup>2</sup>/0.2...2.5 mm<sup>2</sup>

Connection, flexible with connector sleeve ..... 0.25...2.5 mm<sup>2</sup>

**General data**

Operating mode .....	continuous operation
Mounting.....	any position
Protection class, internal components (DIN EN 60529) .....	IP64
Protection class, terminals (DIN EN 60529) .....	IP20
Type of enclosure .....	resin-encapsulated block
Screw mounting.....	M5
Flammability class .....	UL94 V-0
Weight approx. ....	5.1 kg

## 7.4 Data in tabular AGH675S-7MV15

### Insulation coordination in consideration of IEC 61800-5-1:2003

Rated voltage ..... AC 15.5 V

### Voltage test in consideration of IEC 61800-5-1:2003

Type test:

Rated impulse voltage (basic insulation) ..... 111 kV

AC voltage test (basic insulation) ..... 70 kV

Partial discharge test ..... 29 kV

Routine test:

AC voltage test ..... 40 kV

### Voltage ranges

Nominal voltage range  $U_n$  ..... AC, 3(N)AC, DC 0... 15.5 kV

Nominal frequency  $f_n$  ..... 0... 460 Hz

### Environment/EMC

Operating temperature (normal operation) ..... -10... +60 °C

Operating temperature (continuous operation with asymmetrical earth fault) ..... -10... +55 °C

Classification of climatic conditions acc. to IEC 60721:

Stationary use (IEC 60721-3-3) ..... 3K5 (no condensation, no formation of ice)

Transport (IEC 60721-3-2) ..... 2K3

Long-term storage (IEC 60721-3-1) ..... 1K4

Classification of mechanical conditions acc. to IEC 60721:

Stationary use (IEC 60721-3-3) ..... 3M4 (3M7 Y shaft)

Transport (IEC 60721-3-2) ..... 2M2

Long-term storage (IEC 60721-3-1) ..... 1M3

### Connection

Connection terminal 2 (medium voltage) ..... high-voltage cable (encapsulated on the device side)

Connection, flexible with ring terminal ..... M4

Connection terminal 3, 4, 5 ..... screw-type terminals

Connection, rigid, flexible ..... 0.2... 4 mm<sup>2</sup>/0.2... 2.5 mm<sup>2</sup>

Connection, flexible with connector sleeve ..... 0.25... 2.5 mm<sup>2</sup>

**General data**

Operating mode .....	continuous operation
Mounting.....	any position
Protection class, internal components (DIN EN 60529) .....	IP64
Protection class, terminals (DIN EN 60529) .....	IP20
Type of enclosure .....	resin-encapsulated block
Screw mounting.....	M5
Flammability class .....	UL94 V-0
Weight approx. ....	≤ 5100 g



## 7.5 Characteristic curves

### Current output 0...20 mA (IRDH275BM-7)

$R_F$  [k $\Omega$ ]

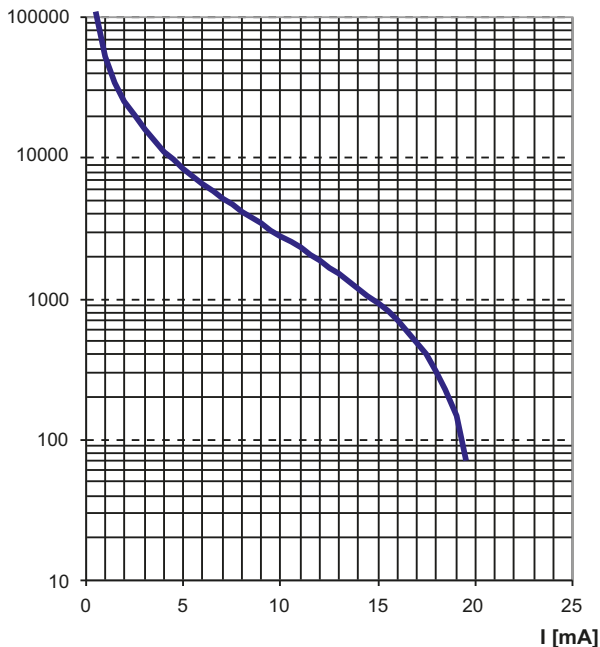

$$R_F = \frac{20 \text{ mA} \times 2800 \text{ k}\Omega}{I} - 2800 \text{ k}\Omega$$

$R_F$  = Insulation fault in k $\Omega$

$I$  = Current output in mA

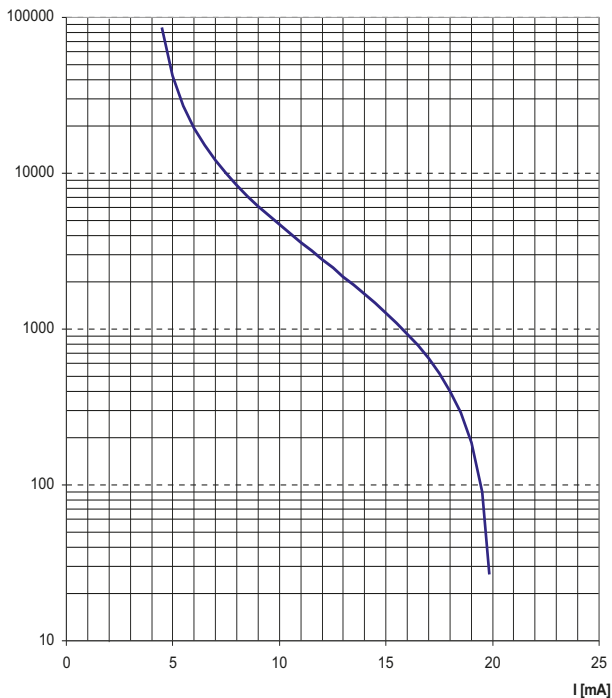
**Current output 4...20 mA (IRDH275BM-7)**
 $R_F$  [k $\Omega$ ]

$$R_F = \frac{16 \text{ mA} \times 2800 \text{ k}\Omega}{I - 4 \text{ mA}} - 2800 \text{ k}\Omega$$

 $R_F$  = Insulation fault in k $\Omega$ 
 $I$  = Current output in mA

**Status number**

Value of the respective number					
Position of numbers from the left	0 =	1 =	2 =	3 =	4 =
1	K1: N/O operation Test	K1: N/C operation Test	K1: flashing function	K1: N/O operation	K1: N/C operation
2	K2: N/O operation Test	K2: N/C operation Test	K2: flashing function	K2: N/O operation	K2: N/C operation
3		AK AGH675S-7			
4	Cemax 0,1 µF **	Cemax 1 µF **	Cemax 2 µF	Cemax 5 µF	
5					
6	Self test every 24 hours	Self test every hour	no periodic self test		
7	Language German	Language English			
8	Password protection not activated	Password protection activated			
9	AMP measuring principle				
10	max. filter frequency 0,1Hz **	max. filter frequency 1Hz **	max. filter frequency 10Hz **	max. filter frequency 50Hz **	
11	min. filter frequency 0,1Hz **	min. filter frequency 1Hz **	min. filter frequency 10Hz **	min. filter frequency 50Hz **	
12	BMS mode **		test data **		
13	Bus address in the tens. place IRDH275				Value: 5 ... 9
14	Bus address in the units. place IRDH275				Value: 5 ... 9
15	Number of pulses 2-9 **				Value: 5 ... 9
	** The parameters marked with two asterisks are settable via the Service menu item! A password is required for that purpose !				

## Dimension diagram enclosure IRDH275

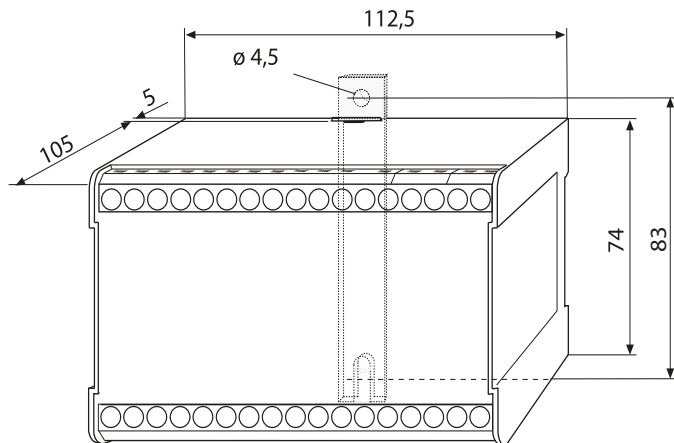

*All dimensions in mm*

- DIN rail mounting according to IEC 60715  
or
- Screw mounting  
by means of a plug-in trapezoidal support  
Order No.: 990056

## Dimension diagram enclosure AGH675S-7 and AGH675S-7MV15

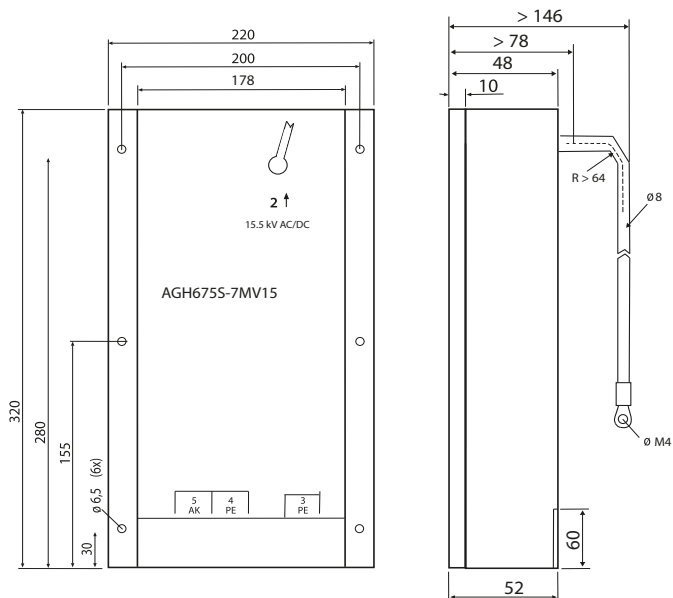

All dimensions in mm

## 7.6 Ordering details

### 7.6.1 ISOMETER® and coupling devices

Type	Nominal voltage $U_n$	Supply voltage $U_s$	Art.-No.	Cable length
IRDH275BM-727	–	AC 19.2...55 V 42...460 Hz DC 19.2...72 V	B91065120	–
AGH675S-7-2000	AC/DC 0...7.2 kV 0...460 Hz	–	B913061	2,000 mm
AGH675S-7-500	AC/DC 0...7.2 kV 0...460 Hz	–	B913060	500 mm
AGH675S-7 MV15-500	AC/DC 0...15.5 kV 0...460 Hz	–	B913058	500 mm

# INDEX

## A

- Activating and setting the password 47
- Alarm LED 1 30
- Alarm LED 2 30
- Alarm messages 55
- Ankoppelgerät
  - Bestellnummern 70
- Automatic self test 42

## B

- Bender Measuring Device Interface 53
- BMS bus
  - correct arrangement 52
  - wrong arrangement 52
- BMS-bus
  - address ranges 56
- BMS-bus address ranges 56
- BMS-Master 53
- BMS-Slave 54

## C

- Changing the measuring principle 42
- Characteristic curves 65
- Characteristics IRDH275BM-7 incl.  
AGH675S-7... 18
- Commissioning of a BMS network 55

Current output 4-20 mA 66

## D

- Dimension diagram enclosure
  - AGH675S-7MV15 69
  - IRDH275 68
- Directions for installation 16
- Display in the menu mode 31
- Display in the standard mode 31

## E

- External coupling devices 42
- External RESET button 28
- External TEST button 28

## F

- Factory setting 17
- Flashing point 54
- Function 19
- Function input F1/F2 23

## H

- How to use this manual 7

## I

- INFO key 30
- Installation of the coupling device  
AGH675S-7... 24

## **M**

Memory database 36  
Memory setting (on/off) 41  
Menu

- COM SETUP 45
- HISTORY INFO 37
- ISO ADVANCED 42
- ISO SETUP 38
- LANGUAGE 49
- PASSWORD 47
- SERVICE 50

Menu structure 35

## **O**

Operating features and displays 30  
Ordering details 70

## **P**

Parameterization via Internet 50  
Product description 19

## **R**

Real-time clock 22  
RESET button 20, 30  
RS-485 interface 51

## **S**

Self test, ISOMETER 30  
Serial interfaces 51  
Service 8  
Setting the bus address for IRDH275B 45  
Setting the date (IRDH275B) 43  
Setting the national language 49

Setting the real-time clock (Clock) 42  
Standards 60  
Status number 67  
Support 8  
system fault LED 21

## **T**

Technical data IRDH275B 57  
TEST button 30  
Topology (IRDH275B) 52  
Training courses 9

## **W**

Wiring 52  
wiring diagram ISOMETER 28  
Work activities on electrical installations 12  
workshops 9  
Wrong arrangement 52











**Bender GmbH & Co. KG**

Londorfer Str. 65 • 35305 Grünberg • Germany

P.O. Box 1161 • 35301 Grünberg • Germany

Tel.: +49 6401 807-0

Fax: +49 6401 807-259

E-mail: [info@bender.de](mailto:info@bender.de)

Web: <http://www.bender.de>

