

# COMTRAXX® CP305 – Control Panel

Remote alarm indicator for medical  
locations and other areas

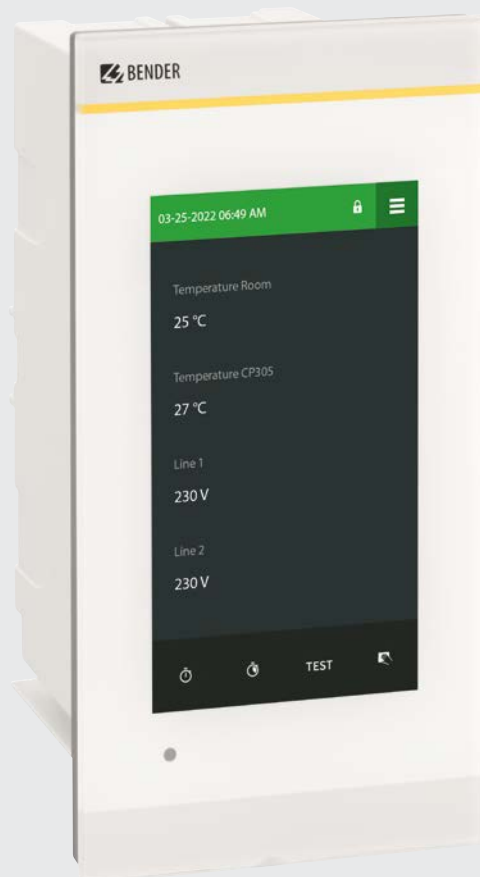

**COMTRAXX® CP305**

### Device features

- 5" touch screen
- Parameter setting via web server, display or Bender Connect app
- Freely programmable alarm messages
- Flush-mounting and surface-mounting version
- Easy replacement MK2007/MK2430 (retrofit)

### Approvals



### Product description

The CP305 is a universal remote alarm indicator for medical locations and other areas. Messages and faults are displayed according to the requirements of IEC 60364-7-710 and DIN VDE 0100-710.

Necessary alarms are indicated visually and audibly.

#### Important display functions:

- Normal operation indicator
- Insulation fault
- Overload
- Overtemperature
- Message from the changeover devices
- Messages from other Bender devices (EDS/RCMS)
- Hazard current
- Device failure
- Test results, isolated power system
- Measured value display

The CP305-IO features an additional 12 digital inputs with which messages and alarms from third-party equipment can be displayed, e.g. medical gases or UPS messages.

The state of the digital inputs can be reported to the building management system via Modbus TCP; furthermore, operating states can be reported to the building management system via 2 relay contacts.

### Functional description

The CP305 can show measured values or individual descriptions on the on the 5" graphic display. The normal, fault-free state of the entire system is indicated by a green LED. In normal state, the display can be switched off to save energy and avoid unnecessary illumination.

In the event of an alarm, the display is activated and shows the corresponding alarm message in addition to the set alarm colour. Additionally (if parameterised) the alarm can be signalled acoustically. The CP305 can also be used as a parallel display.

The CP305 can act as a master in a Bender system (BMS) or take over the master function if the master fails.

The test function can be used to check connected ISOMETER®s.

Parameters can be set conveniently via the integrated web server. Further parameterisation is possible via the display or the Bender Connect app.

### Display and operation

Intuitive operation via the display. Timer and stopwatch are integrated and can be used directly in the room if necessary. The timer emits an adjustable signal when it expires.

All relevant messages are displayed when they are needed.

In the event of an alarm, the display changes from idle mode to alarm mode and outputs the set colours, signals and alarm messages.

Audible signals can be muted via the display. Even during a pending alarm, it is possible to navigate through the menus, history memories and displays.

### Device variants

#### CP305

The CP305 is used to display visual and audible alarms. ISOMETER®s can be tested via the test function. The CP305 can also be used as a parallel display in combination with other CP305 or CP9xx.

In the event of an alarm, the programmed alarm messages are shown on the display.

#### CP305-IO

The CP305-IO features 12 digital inputs that can be freely assigned. This allows messages from third-party equipment such as battery systems or the state of medical gases to be indicated.

Any alarm message can be assigned to the inputs.

The CP305-IO has 2 additional relay outputs.

**Parameter setting**

Basic settings can be made directly on the device using a commissioning wizard.

Alarm and test addresses can be configured with both standard and individual texts. The required web server is already integrated.

**History memory**

Up to 1,000 entries can be stored in the history memory, after which the entries are overwritten chronologically. The memory can be read out via the web server or on the display.

**Wiring diagram**

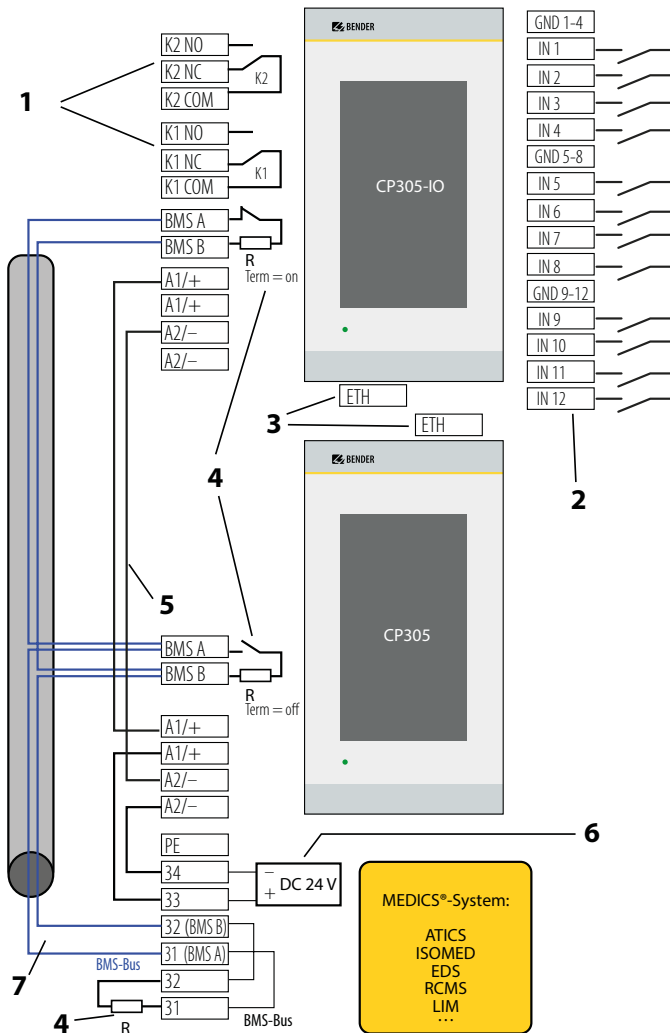

- 1 - K...COM** **2 Relay outputs**  
**K...NC** Parametrisable contacts for device errors, test of assigned devices\*, device failure and common alarm message.  
**K...NO**
- 2 - IN1...12** **Digital inputs**  
**GND...** The digital inputs are divided into three groups of four, which are galvanically separated from each other and from the device. Each group has its own GND terminal for the reference potential.  
 The digital inputs may be activated either via internal or external voltage or potential-free contacts. If the inputs are controlled via an external voltage, the common reference potential is connected to the "GND" terminal and the signal is connected to the respective input IN1...12.
- 3 - ETH** **Ethernet interface** for connection to a PC  
 The CP305 can be integrated into the Bender/hospital network via the Ethernet interface. Parameters can be set on the PC and data as well as the history memory can be read out. Connected measuring devices can be displayed with their channels.
- 4 - R** **BMS bus terminating resistor**  
 If two or more devices are connected to each other via the BMS bus, the bus line must be terminated at both ends with a resistor ( $R = 120 \Omega$ ). (On the CP305, the resistors can be enabled via a switch at the bottom).
- 5 - A1+/A2-** **Supply voltage**  
 For the supply of the CP305 in the MEDICS® modules, observe the permissible cable lengths and cross-sections.
- 6 - DC 24 V** **Power supply unit** in the MEDICS® module, sufficient for supplying power to max two CP305.
- 7 - BMS A** **BMS bus connection**  
**BMS B** Various Bender devices with a BMS bus interface can be connected to the BMS bus. Examples: ATICS®, isoMED427P, EDS151, RCMS..., CP9xx, ...

\* Devices without BMS bus connection, but with test input (e.g. ISOMETER®)

## Technical data

### Insulation coordination CP305 acc. to IEC 60664-1

Rated voltage	50 V
Overvoltage category	II
Pollution degree	2

Overvoltage category II and pollution degree 2 is related to the relay contacts.  
Further insulation coordination takes place after functional separation.

### Supply via plug-in terminal (A1 +/-A2 -)

Nominal voltage	AC/DC 24 V
Operating range of the supply voltage	AC 18...28 V / DC 18...30 V
Nominal frequency	50/60 Hz
Typical power consumption	< 4.2 W
Maximum cable length when supplied via B95061210 (24 V DC power supply unit 1.75 A)	
0.28 mm <sup>2</sup>	75 m
0.5 mm <sup>2</sup>	130 m
0.75 mm <sup>2</sup>	200 m
1.5 mm <sup>2</sup>	400 m
2.5 mm <sup>2</sup>	650 m

### Stored energy time in the event of voltage failure

Time, date	min. 2 days
Restart after power failure	min. 2 seconds

### Displays, memory

Display	5" TFT touch display (720 x 1280 px)
Displayable devices	90
Alarm addresses	500
Number of history memory entries	1,000

### Interfaces

#### Ethernet

Connection	RJ45
Data rate	10/100 Mbit/s, autodetect
DHCP	on/off (off)*
IP address (1:1 connection)	169.254.xx.yy (xx and yy individual for each device)
Net mask	nnn.nnn.nnn.nnn (255.255.0.0)*
Protocols	TCP/IP, Modbus TCP, DHCP, SNMP

#### Modbus TCP (CP305-IO only)

Interface/protocol	Ethernet/Modbus TCP
Operating mode	Slave

#### BMS bus

Interface/Protocol	RS485/BMS internal
Operating mode	master/slave (master)*
Baud rate	9.6 kbit/s
Cable length	< 1200 m
Shielded cable, one end of shield connected to PE recommended: CAT6/CAT7 min. AWG23	alternative: J-Y(St)Y min. 2 x 0.8
Galvanic separation	yes
Connection	"BMS A", "BMS B" (see plug-in terminal)
Terminating resistor	120 Ω (0.25 W), can be connected internally
Device address	1...90 (1)*

### Digital inputs (1...12)

Number	12
Galvanic separation	yes
Operating mode	selectable for each input: active-high or active-low
Factory setting	off
Voltage range (high)	AC/DC 10...30 V Nominal: 24 V
Voltage range (low)	AC/DC 0...2 V
Max. current per channel (at AC/DC 30 V)	8 mA
Connection	plug-in terminals IN 1...4 / GND1-4 IN 5...8 / GND 5-8 IN 9...12 / GND 9-12
Maximum cable length	< 1000 m

### Switching elements

Connection	plug-in terminal K1 NC; K1 NO; K1 COM K2 NC; K2 NO; K2 COM
Number of changeover contacts	2
Operating mode (changeover contacts)	N/C operation or N/O operation
Function	programmable
Electrical endurance under rated operating conditions, number of cycles	10,000
Minimum contact load (relay manufacturer's reference)	–

### Contact data acc. to IEC 60947-5-1

Utilisation category	AC-13	AC-14	DC-12
Rated operational voltage	AC 24 V	AC 24 V	DC 24 V
Rated operational current	AC 2 A	AC 2 A	AC 2 A

### Buzzer

Buzzer alarm	can be acknowledged, adoption of characteristics of new value, can be muted
Buzzer interval	configurable
Buzzer frequency	configurable
Buzzer repetition	configurable

### Device connections

#### Plug-in terminal (A1/+; A2/-)

Conductor sizes	AWG 24...12
Stripping length	10 mm
rigid/flexible	0.2...2.5 mm <sup>2</sup>
flexible with ferrule with/without plastic sleeve	0.25...2.5 mm <sup>2</sup>
Multiple conductor, flexible with TWIN ferrule with plastic sleeve	0.5...1.5 mm <sup>2</sup>

#### Plug-in terminal, CP305-IO only

(IN1...4, GND1...4, IN9...12, GND9...12)(IN5...8, GND5...8, K1..., K2...)(BMS A, BMS B)	
Conductor sizes	AWG 24...16
Stripping length	10 mm
rigid/flexible	0.2...1.5 mm <sup>2</sup>
flexible with ferrule without plastic sleeve	0.25...1.5 mm <sup>2</sup>
flexible with ferrule without plastic sleeve	0.25...0.75 mm <sup>2</sup>

### For UL applications

Use copper lines only.	
Minimum temperature range of the cable to be connected to the plug-in terminals	75 °C

**Environment/EMC**

EMC	IEC 61326-1, 61000-6-2, 61000-6-3, Lloyd's Register, EN 300 330, EN 301 489-3
Operating temperature	-10...+55 °C
Operating temperature for UL applications	-10...+50 °C
Operating altitude	≤ 2000 m AMSL
Rel. humidity	≤ 98 %

**Classification of climatic conditions acc. to IEC 60721**

Stationary use (IEC 60721-3-3)	3K22
Transport (IEC 60721-3-2)	2K11
Long-term storage (IEC 60721-3-1)	1K22

**Classification of mechanical conditions acc. to IEC 60721**

Stationary use (IEC 60721-3-3)	3M11
Transport (IEC 60721-3-2)	2M4
Long-term storage (IEC 60721-3-1)	1M12

**Other**

Operating mode	continuous operation
Mounting position	any position
	Display orientation adjustable
Degree of protection, front	IP54
Degree of protection, front for UL applications	IP50
Degree of protection, enclosure	IP20
Flammability class	UL 94V-0
Device dimensions (W x D x H)	181 x 96 x 37.1 mm
Weight	< 420 g

**Ordering information**

Type	Art. No.
CP305	B95100050
CP305-IO	B95100051

**Accessories**

Description	Art. No.
Flush-mounting enclosure	B923710
Cavity-wall installation set for flush-mounting enclosures	B923711
CP305 surface-mounting enclosure	B95100153
CP305 plug kit	B95100150
CP305-IO plug kit	B95100151
Ethernet adapter kit (RJ45 socket insert, Cat.6 SLIM patch cable)	B95100152

**Dimension diagram**

Dimensions in mm

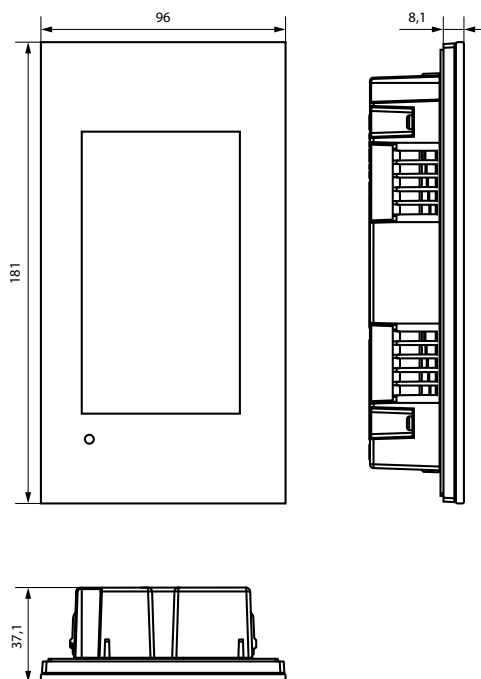

**Dimension diagram flush-mounting version**

Dimensions in mm

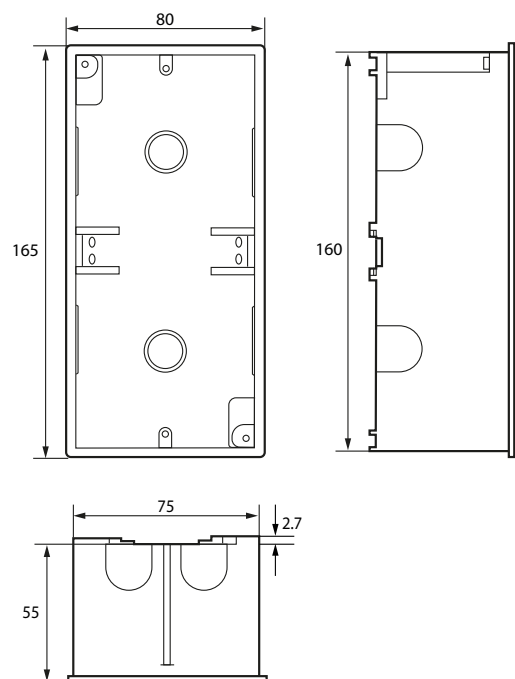

## Connection example BMS and Ethernet

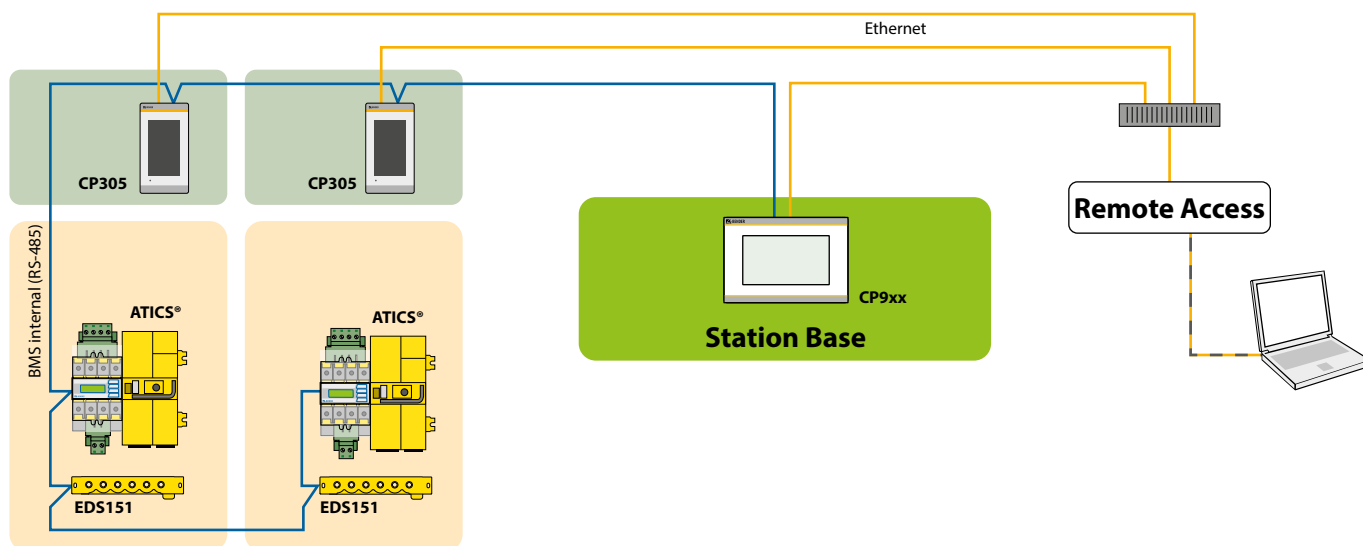

**optec**  
energie ist messbar

Optec AG | Guyer-Zeller-Strasse 14 | CH-8620 Wetzikon ZH

Telefon: +41 44 933 07 70 | E-Mail: info@optec.ch  
www.optec.ch



### Bender GmbH & Co. KG

Londorfer Straße 65 • 35305 Grünberg • Germany  
Tel.: +49 6401 807-0 • info@bender.de • www.bender.de



**BENDER Group**