

LINETRAXX® VMD420

Multi-functional voltage relay for 3(N)AC systems,
frequency/overvoltage/undervoltage, phase, phase failure, asymmetry



LINETRAXX® VMD420

Multi-functional voltage relay for frequency, overvoltage, undervoltage, phase sequence, phase failure and asymmetry monitoring in 3(N)AC systems



LINETRAXX® VMD420

Device features

- Undervoltage, overvoltage and frequency monitoring in 3(N)AC systems 0...500 V
- Asymmetry, phase failure and phase sequence monitoring
- Various monitoring functions selectable < U, > U, < f, > f
- Start-up delay, response delay and delay on release
- Adjustable switching hysteresis
- r.m.s. value measurement (AC+DC)
- Digital measured value display via multi-functional LC display
- Preset function (automatic setting of basic parameters)
- LEDs: Power On, Alarm 1, Alarm 2
- Measured value memory for operating value
- Continuous self monitoring
- Internal test/reset button
- Two separate alarm relays (one changeover contact each)
- N/C or N/O operation and fault memory behaviour selectable
- Password protection for device setting
- Sealable transparent cover
- Two-module enclosure (36 mm)
- Push-wire terminal (two terminals per connection)
- RoHS compliant

Approvals



Product description

The multi-functional VMD420 series voltage relay is designed to monitor the frequency, undervoltage and overvoltage and the voltage between two threshold values in 3(N)AC systems. The voltages are measured as r.m.s. values. The currently measured value is continuously shown on the LC display. The measured value required to trigger the alarm relay is stored. Due to adjustable response times, installation-specific characteristics, such as device-specific start-up procedures, short-time voltage fluctuations, etc. can be considered. The devices require an external supply voltage.

Typical applications

- Monitoring of voltage-sensitive machines and electrical installations
- Switching machinery and equipment on and off at a certain voltage level
- Monitoring of stand-by and emergency supply systems
- Supply voltage monitoring of portable loads
- Protection of three-phase motors against phase failure and phase open-circuit
- Transformer protection, asymmetrical load can be recognised

Function

Once the supply voltage is applied, the start-up delay "t" begins. Measured voltage and frequency values changing during this time do not influence the switching state of the alarm relays.

The devices feature two separately adjustable measuring channels (overvoltage/undervoltage). When the measuring quantity exceeds the response value ("Alarm 1") or falls below the response value ("Alarm 2"), the time of the response delays "t_{on1/2}" begins. Once the response delay has elapsed, the alarm relays switch and the alarm LEDs light up. When the measuring value exceeds or falls below the release value (response value plus hysteresis) after the alarm relays have switched, the selected release time "t_{off}" begins. When "t_{off}" has elapsed, the alarm relays switch back to their initial position. When the fault memory is activated, the alarm relays remain in alarm position until the reset button "R" is pressed. When the fault memory is set to continuous mode, the alarm parameters remain stored, even on failure of the supply voltage.

Preset function

After connecting the device for the first time, the nominal system voltage will be determined (PrE run), and the response values for overvoltage and undervoltage as well as for under-frequency and overfrequency will automatically be set. When no voltage is determined within a nominal system voltage range (PrE run), the response values will be set to the minimum or maximum voltage. In this case, the message "AL not SET" appears on the display. As long as no button is pressed, a nominal system voltage is being searched cyclically (PrE run). If a button is pressed, the search will be interrupted and the message "AL not SET" disappears. In this case, the appropriate response values have to be set in the menu. When activating the frequency monitoring function, the preset frequency will automatically be stored.



Operating elements

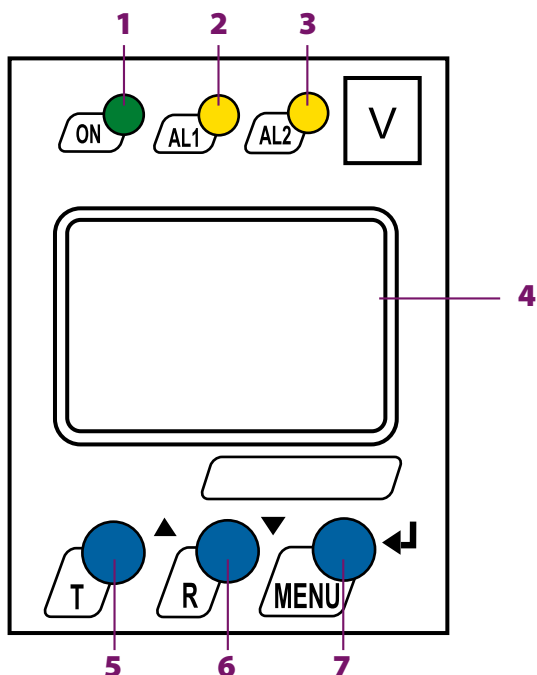

- 1 - Power On LED "ON" (green); lights when supply voltage is applied and flashes in the event of system fault alarm
- 2 - Alarm LED "AL1" (yellow), lights when the set response value $>U/<f>/f >f/Asy/PHS$ is exceeded and flashes in the event of system fault alarm
- 3 - Alarm LED "AL2" (yellow), lights when the set response value $>U/<f>/f >f/Asy/PHS$ is exceeded and flashes in the event of system fault alarm
- 4 - Multi-functional LC display
- 5 - Test button "T":
Arrow up button: to change the measured value display, move upwards in the menu or to change parameters
To call up the self test: press the button "T" >1.5 s
- 6 - Reset button "R":
Arrow down button: to change the measured value display, move downwards in the menu or to change parameters
To delete stored alarms: press the button "T" >1.5 s
- 7 - "MENU" button:
Enter button: to confirm the measured value indication or to confirm changed parameters
To call up the menu system, press the button "T" >1.5 s
Press the ESC button >1.5 s to abort an action or to return to the previous menu level

When the menu item LEd is activated, the alarm LED "AL1" indicates that K1 is in the alarm state. When "AL2" lights up, K2 is in the alarm position.

Wiring diagram

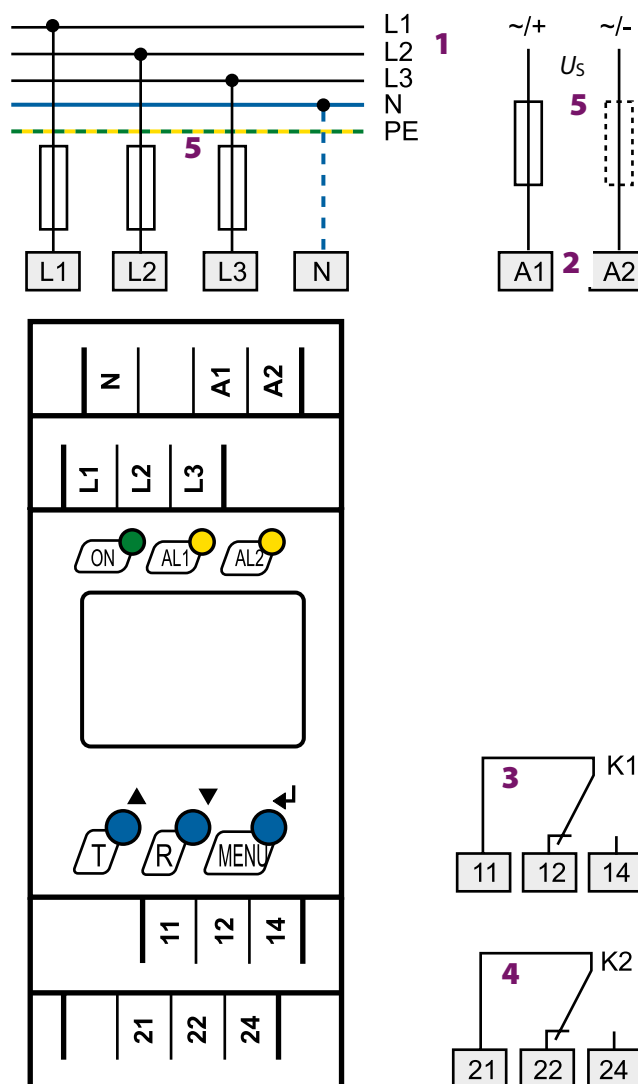

- 1 - Connection to the system/load to be monitored
- 2 - Supply voltage U_s (see ordering information)
- 3 - Alarm relay "K1":
Configurable for $<U/>U/<f>/f/Asy/PHS/ERROR$
- 4 - Alarm relay "K2":
Configurable for $<U/>U/<f>/f/Asy/PHS/ERROR$
- 5 - Fuse as line protection.
6 A fuse recommended. If being supplied from an IT system, both lines have to be protected by a fuse.

Ordering information

Supply voltage ¹⁾ U _S		Type	Art. No.
AC	DC		
16...72 V, 15...460 Hz	9,6...94 V	VMD420-D-1	B 7301 0005
70...300 V, 15...460 Hz	70...300 V	VMD420-D-2	B 7301 0006

Device version with screw terminals on request.

¹⁾ Absolut values

Accessories

Type designation	Art. No.
Mounting clip for screw mounting (1 piece per device)	B 9806 0008

Dimension diagram XM420

Dimensions in mm
Open the front plate cover in direction of arrow!

Screw mounting

Note: The upper mounting clip must be ordered separately (see ordering information).

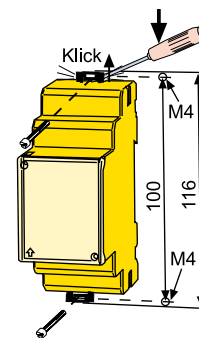
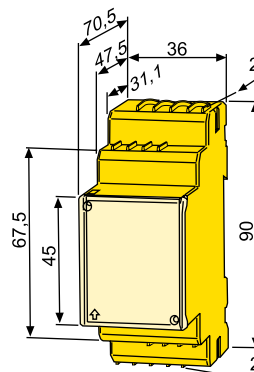

Technical data
Insulation coordination acc. to IEC 60664-1/IEC 60664-3

Rated insulation voltage	400 V
Rated impulse voltage/pollution degree	4 kV/3
Overtoltage category	III
Protective separation (reinforced insulation) between (A1, A2) - (N, L1, L2, L3) - (11, 12, 14) - (21, 22, 24)	
Voltage test acc. to IEC 61010-1: (N, L1, L2, L3) - (A1, A2), (11, 12, 14)	3.32 kV
(N, L1, L2, L3) - (21, 22, 24)	2.21 kV
(A1, A2) - (11, 12, 14) - (21, 22, 24)	2.21 kV

Supply voltage
VMD420-D-1:

Supply voltage U_s	AC 16...72 V/DC 9.6...94 V
Frequency range U_s	15...460 Hz

VMD420-D-2:

Supply voltage U_s	AC/DC 70...300 V
Frequency range U_s	15...460 Hz
Power consumption	≤ 4 VA

Measuring circuit

Measuring range (r.m.s. value) (L-N)	AC 0...288 V
Measuring range (r.m.s. value) (L-L)	AC 0...500 V
Rated frequency f_n	15...460 Hz
Frequency display range	10...500 Hz

Response values

Type of distribution system	3(N)AC/3AC (3AC)*
Undervoltage < U (Alarm 2) (measurement method:	AC 6...500/6...288 V
Overtoltage > U (Alarm 1) (measurement method: 3Ph/3n)	AC 6...500/6...288 V
Resolution of setting U	1 V

Preset function for 3AC measurement:

Undervoltage < U (0.85 U_n)* for $U_n = 400/208$ V	340/177 V
Overtoltage > U (1.1 U_n)* for $U_n = 400/208$ V	440/229 V

Preset function for 3(N)AC measurement:

Undervoltage < U (0.85 U_n)* for $U_n = 230/120$ V	196/102 V
Overtoltage > U (1.1 U_n)* for $U_n = 230/120$ V	253/132 V

Asymmetry	5...30 % (30 %)*
Phase failure	by setting the asymmetry
Phase sequence	clockwise/anticlockwise rotation (off)*
Relative uncertainty, voltage at 50/60 Hz	± 1.5 %, ± 2 digits
Relative uncertainty, voltage in the range 15...460 Hz	± 3 %, ± 2 digits
Hysteresis U	1...40 % (5 %)*
Underfrequency < Hz	10...500 Hz**
Overfrequency > Hz	10...500 Hz**
Resolution of setting f (10.0...99.9 Hz)	0.1 Hz
Resolution of setting f (100...500 Hz)	1 Hz

Preset function:

Underfrequency for $f_n = 400/60/50/16.7$ Hz	399/59/49/15.7 Hz
Overfrequency for $f_n = 400/60/50/16.7$ Hz	401/61/51/17.7 Hz
Hysteresis, frequency Hys Hz	0.1...2 Hz (0.2 Hz)*
Relative uncertainty, frequency range 15...460 Hz	± 0.2 %, ± 1 digit

Time response

Start-up delay t	0...300 s (0 s)*
Response delay $t_{on/2}$	0...300 s (0 s)*
Delay on release t_{off}	0...300 s (0.5 s)*
Resolution of setting $t, t_{on/2}, t_{off}$ (0...10 s)	0.1 s
Resolution of setting $t, t_{on/2}, t_{off}$ (10...99 s)	1 s
Resolution of setting $t, t_{on/2}, t_{off}$ (100...300 s)	10 s
Operating time, voltage t_{ae}	≤ 140 ms
Operating time, frequency t_{ae}	≤ 335 ms
Response time t_{an}	$t_{an} = t_{ae} + t_{on/2}$
Recovery time t_b	≤ 300 ms

Displays, memory

Display	LC display, multifunctional, not illuminated
Display range measured value	AC/DC 0...500 V
Operating uncertainty, voltage at 50 Hz/60 Hz	1.5 %, 2 digits
Operating uncertainty voltage in the range of 15...460 Hz	± 3 %, ± 2 digits
Operating uncertainty, frequency in the range of 15...460 Hz	± 0.2 %, ± 1 digit
History memory (HiS) for the first alarm value	data record measured values
Password	off/0...999 (off/0)*
Fault memory (M) alarm relay	on/off/con (on)*

Switching elements

Number	2 x 1 changeover contacts (K1, K2)
Operating principle	N/C operation n.c. or N/O operation n.o.
K2: Err, < U , > U , Asy, < Hz, > Hz, PHS, S.AL (undervoltage < U , asymmetry Asy, N/C operation n.c.)*	
K1: Err, < U , > U , Asy, < Hz, > Hz, PHS, S.AL (overtoltage > U , asymmetry Asy, N/O operation n.o.)*	
Electrical endurance, number of cycles	10000
Contact data acc. to IEC 60947-5-1:	
Utilisation category	AC 13 AC 14 DC-12 DC-12 DC-12
Rated operational voltage	230 V 230 V 24 V 110 V 220 V
Rated operational current	5 A 3 A 1 A 0.2 A 0.1 A
Minimum contact rating	1 mA at AC/DC ≥ 10 V

Environment/EMC

EMC	IEC61326-1
Operating temperature	-25...+55 °C
Classification of climatic conditions acc. to IEC 60721:	
Stationary use (IEC 60721-3-3)	3K5 (no condensation, no formation of ice)
Transport (IEC 60721-3-2)	2K3
Long-term storage (IEC 60721-3-1)	1K4
Classification of mechanical conditions acc. to IEC 60721:	
Stationary use (IEC 60721-3-3)	3M4
Transport (IEC 60721-3-2)	2M2
Long-term storage (IEC 60721-3-1)	1M3

Connection

Connection type	push-wire terminals
Connection properties	
rigid	0.2...2.5 mm ² (AWG 24...14)
flexible without ferrule	0.75...2.5 mm ² (AWG 19...14)
flexible with ferrule	0.2...1.5 mm ² (AWG 24...16)
Stripping length	10 mm
Opening force	50 N
Test opening, diameter	2.1 mm

Other

Operating mode	continuous operation
Mounting	any position
Degree of protection, internal components (DIN EN 60529)	IP30
Degree of protection, terminals (DIN EN 60529)	IP20
Enclosure material	polycarbonate
Screw mounting	2 x M4 with mounting clip
DIN rail mounting acc. to	IEC 60715
Flammability class	UL94 V-0
Documentation number	D00137
Weight	≤ 150 g

(*) = factory setting

** = The technical data can only be ensured in the operating range of the nominal frequency 15...460 Hz.

optec
energie ist messbar

Optec AG | Guyer-Zeller-Strasse 14 | CH-8620 Wetzikon ZH

Telefon: +41 44 933 07 70 | Telefax: +41 44 933 07 77
E-Mail: info@optec.ch | Internet: www.optec.ch



Bender GmbH & Co. KG

P.O. Box 1161 • 35301 Gruenberg • Germany
Londorfer Strasse 65 • 35305 Gruenberg • Germany
Tel.: +49 6401 807-0 • Fax: +49 6401 807-259
E-Mail: info@bender.de • www.bender.de



BENDER Group